

Figure 1

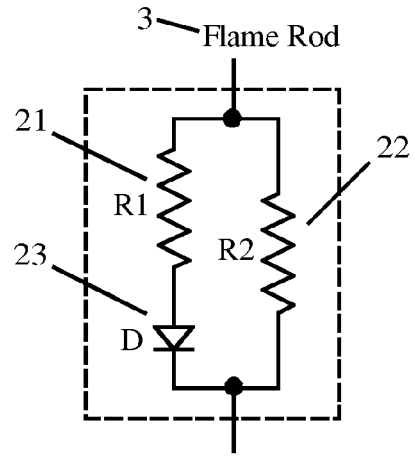

Figure 2

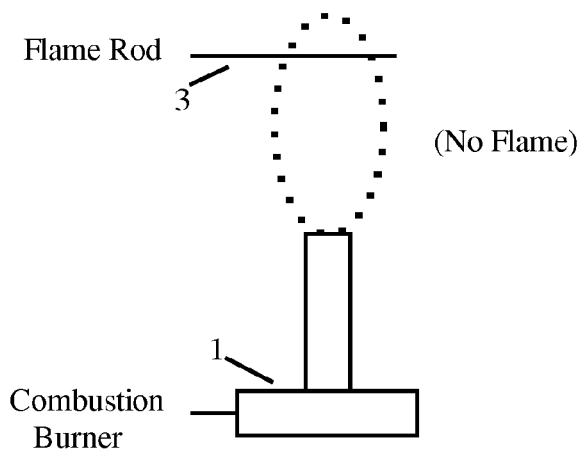

Figure 3

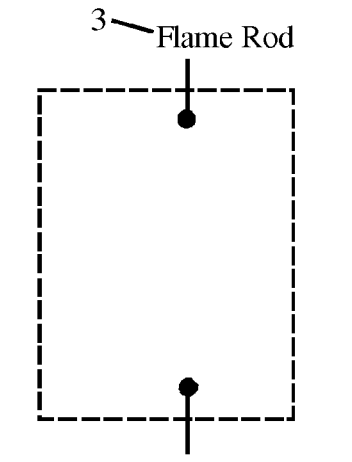

Figure 4

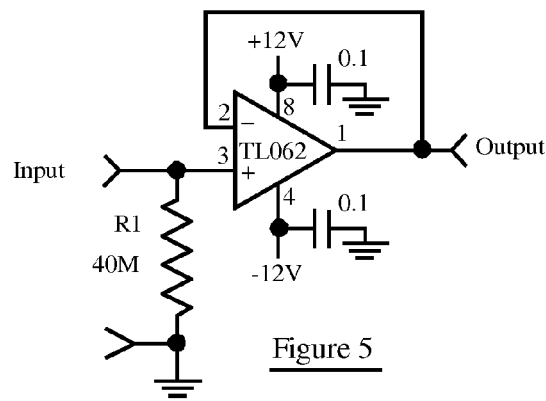
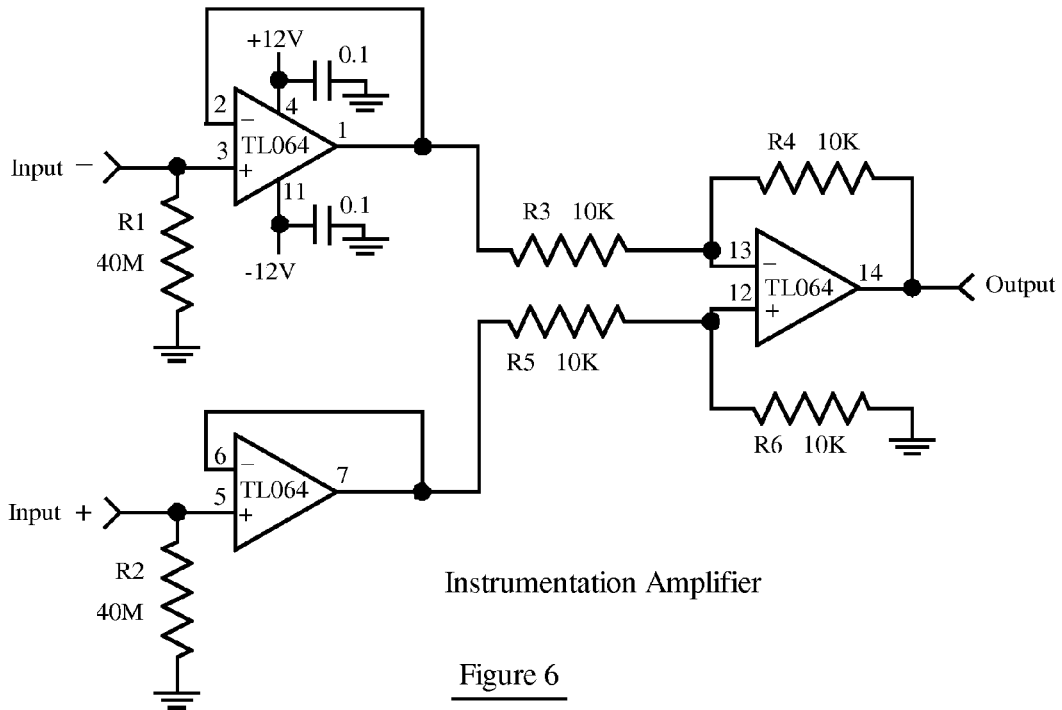

Figure 5



Instrumentation Amplifier

Figure 6

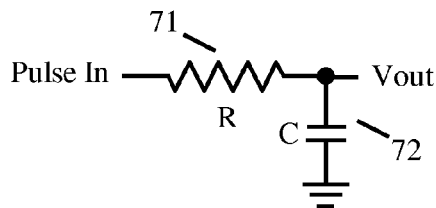

Figure 7

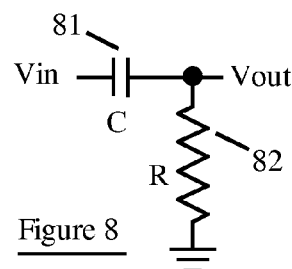

Figure 8

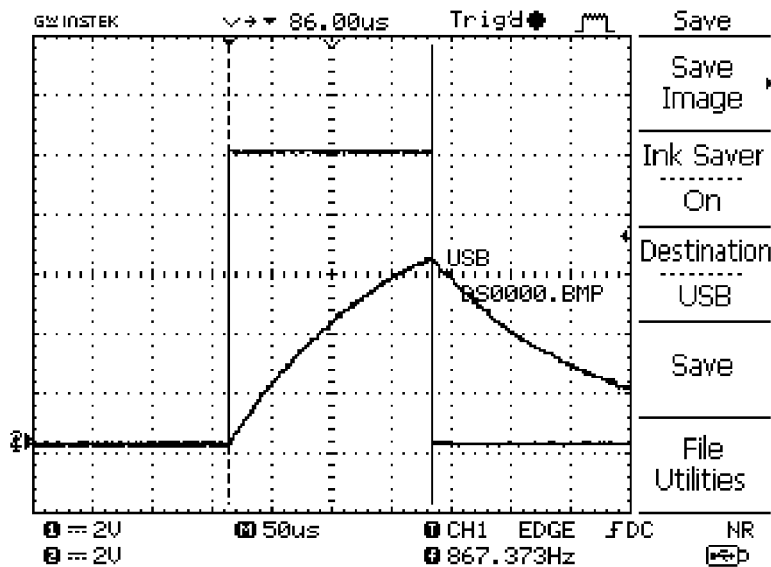

Figure 9

Table 2

$$\frac{V_{out}}{V_{in}} = \frac{R}{R + 1/(s*C)} \quad H(s) = \frac{s}{s + 1/(R*C)}$$

Substitute $s = j\omega$

$$H(j\omega) = \frac{j\omega}{j\omega + 1/(R*C)}$$

$$\text{The magnitude response } |H(j\omega)| = \frac{\omega}{\text{Sqrt}(\omega^2 + 1/(R*C)^2)}$$

$$\text{The Phase Response } \theta(j\omega) = 90^\circ - \tan^{-1}(\omega*R*C)$$

Where $\omega = 2 * \pi * \text{Frequency}$

Therefore, for

- $V_{in} = 120 \text{ VAC}$ (120)
- $R = 1 \text{ megohm}$ ($1*10^6$)
- $C = 160 \text{ pF}/10*2.5$ ($40*10^{-12}$)
- $\text{Frequency} = 60 \text{ Hz}$ (60)

The magnitude of V_{out} is approximately 1.81 VAC
 The phase response is a phase lead of approximately 8.9 degrees.

Figure 10

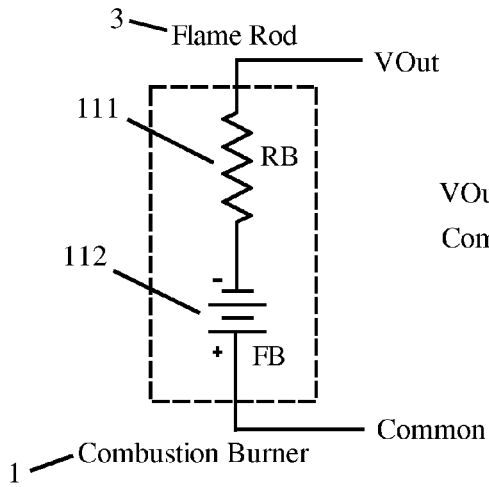

Figure 11

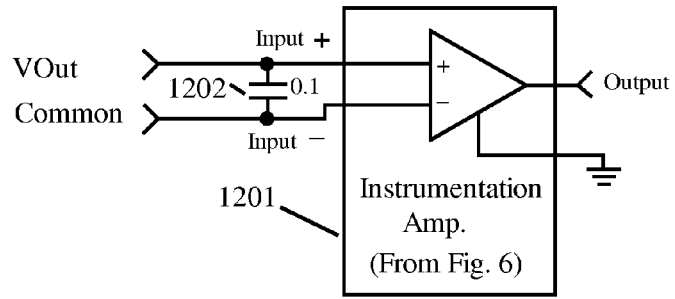

Figure 12

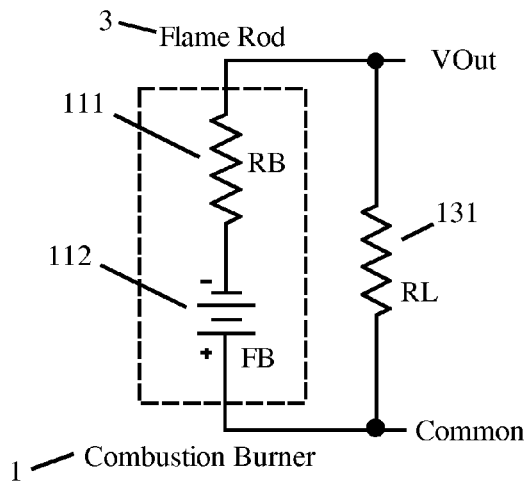

Figure 13

Table 5.4 (continued)

No.	Reaction	Forward Rate Coefficient*		
		A	b	E
<i>N-Containing Reactions (continued)</i>				
201	$\text{NH}_2 + \text{O} \rightarrow \text{H} + \text{HNO}$	3.9E + 13	0.0	0.0
202	$\text{NH}_2 + \text{H} \rightarrow \text{NH} + \text{H}_2$	4.00E + 13	0.0	3,650
203	$\text{NH}_2 + \text{OH} \rightarrow \text{NH} + \text{H}_2\text{O}$	9.00E + 07	1.5	-460
204	$\text{NNH} \rightarrow \text{N}_2 + \text{H}$	3.30E + 08	0.0	0.0
205	$\text{NNH} + \text{M} \rightarrow \text{N}_2 + \text{H} + \text{M}$	1.30E + 14	-0.1	4,980
206	$\text{NNH} + \text{O}_2 \rightarrow \text{HO}_2 + \text{N}_2$	5.00E + 12	0.0	0.0
207	$\text{NNH} + \text{O} \rightarrow \text{OH} + \text{N}_2$	2.50E + 13	0.0	0.0
208	$\text{NNH} + \text{O} \rightarrow \text{NH} + \text{NO}$	7.00E + 13	0.0	0.0
209	$\text{NNH} + \text{H} \rightarrow \text{H}_2 + \text{N}_2$	5.00E + 13	0.0	0.0
210	$\text{NNH} + \text{OH} \rightarrow \text{H}_2\text{O} + \text{N}_2$	2.00E + 13	0.0	0.0
211	$\text{NNH} + \text{CH}_3 \rightarrow \text{CH}_4 + \text{N}_2$	2.50E + 13	0.0	0.0
212	$\text{H} + \text{NO} + \text{M} \rightarrow \text{HNO} + \text{M}$	4.48E + 19	-1.3	740
213	$\text{HNO} + \text{O} \rightarrow \text{NO} + \text{OH}$	2.50E + 13	0.0	0.0
214	$\text{HNO} + \text{H} \rightarrow \text{H}_2 + \text{NO}$	9.00E + 11	0.7	660
215	$\text{HNO} + \text{OH} \rightarrow \text{NO} + \text{H}_2\text{O}$	1.30E + 07	1.9	-950
216	$\text{HNO} + \text{O}_2 \rightarrow \text{HO}_2 + \text{NO}$	1.00E + 13	0.0	13,000
217	$\text{CN} + \text{O} \rightarrow \text{CO} + \text{N}$	7.70E + 13	0.0	0.0
218	$\text{CN} + \text{OH} \rightarrow \text{NCO} + \text{H}$	4.00E + 13	0.0	0.0
219	$\text{CN} + \text{H}_2\text{O} \rightarrow \text{HCN} + \text{OH}$	8.00E + 12	0.0	7,460
220	$\text{CN} + \text{O}_2 \rightarrow \text{NCO} + \text{O}$	6.14E + 12	0.0	-440
221	$\text{CN} + \text{H}_2 \rightarrow \text{HCN} + \text{H}$	2.95E + 05	2.5	2,240
222	$\text{NCO} + \text{O} \rightarrow \text{NO} + \text{CO}$	2.35E + 13	0.0	0.0
223	$\text{NCO} + \text{H} \rightarrow \text{NH} + \text{CO}$	5.40E + 13	0.0	0.0
224	$\text{NCO} + \text{OH} \rightarrow \text{NO} + \text{H} + \text{CO}$	2.50E + 12	0.0	0.0
225	$\text{NCO} + \text{N} \rightarrow \text{N}_2 + \text{CO}$	2.00E + 13	0.0	0.0
226	$\text{NCO} + \text{O}_2 \rightarrow \text{NO} + \text{CO}_2$	2.00E + 12	0.0	20,000
227	$\text{NCO} + \text{M} \rightarrow \text{N} + \text{CO} + \text{M}$	3.10E + 14	0.0	54,050
228	$\text{NCO} + \text{NO} \rightarrow \text{N}_2\text{O} + \text{CO}$	1.90E + 17	-1.5	740
229	$\text{NCO} + \text{NO} \rightarrow \text{N}_2 + \text{CO}_2$	3.80E + 18	-2.0	800
230	$\text{HCN} + \text{M} \rightarrow \text{H} + \text{CN} + \text{M}$	1.04E + 29	-3.3	126,600
231	$\text{HCN} + \text{O} \rightarrow \text{NCO} + \text{H}$	2.03E + 04	2.6	4,980
232	$\text{HCN} + \text{O} \rightarrow \text{NH} + \text{CO}$	5.07E + 03	2.6	4,980
233	$\text{HCN} + \text{O} \rightarrow \text{CN} + \text{OH}$	3.91E + 09	1.6	26,600
234	$\text{HCN} + \text{OH} \rightarrow \text{HOCN} + \text{H}$	1.10E + 06	2.0	13,370
235	$\text{HCN} + \text{OH} \rightarrow \text{HNCO} + \text{H}$	4.40E + 03	2.3	6,400
236	$\text{HCN} + \text{OH} \rightarrow \text{NH}_2 + \text{CO}$	1.60E + 02	2.6	9,000
237	$\text{H} + \text{HCN} + \text{M} \rightarrow \text{H}_2\text{CN} + \text{M}$		pressure dependent	
238	$\text{H}_2\text{CN} + \text{N} \rightarrow \text{N}_2 + \text{CH}_2$	6.00E + 13	0.0	400
239	$\text{C} + \text{N}_2 \rightarrow \text{CN} + \text{N}$	6.30E + 13	0.0	46,020
240	$\text{CH} + \text{N}_2 \rightarrow \text{HCN} + \text{N}$	3.12E + 09	0.9	20,130
241	$\text{CH} + \text{N}_2 (+ \text{M}) \rightarrow \text{HCNN} (+ \text{M})$		pressure dependent	
242	$\text{CH}_2 + \text{N}_2 \rightarrow \text{HCN} + \text{NH}$	1.00E + 13	0.0	74,000
243 ^b	$\text{CH}_2(\text{S}) + \text{N}_2 \rightarrow \text{NH} + \text{HCN}$	1.00E + 11	0.0	65,000

Figure 14 (from Turns)

Table 1

Table 17.12 Composition (mol%) and properties of natural gas from sources in the United States [28]^a

Location	CH ₄	C ₂ H ₆	C ₃ H ₈	C ₄ H ₁₀	CO ₂	N ₂	Density ^c (kg/m ³)	HHV ^d (kJ/M ³)	HHV ^d (kJ/hg)
Alaska	99.6	—	—	—	—	0.4	0.686	37,590	54,800
Birmingham,	90.0	5.0	—	—	—	5.0	0.735	37,260	50,690
East Ohio ^b	94.1	3.01	0.42	0.28	0.71	1.41	0.723	38,260	52,940
Kansas City,	84.1	6.7	—	—	0.8	8.4	0.772	36,140	46,830
Pittsburgh,	83.4	15.8	—	—	—	0.8	0.772	41,840	54,215

^a Although not explicitly stated in Ref. [28], these gases appear to be pipeline gases.
^b Also contains 0.01 % H₂ and 0.01% O₂.
^c At 1 atm and 15.6°C (60 F).
^d Higher heating values for 1 atm and 15.6°C (60 F) [28].

Figure 15 (Turns Table 17.12)

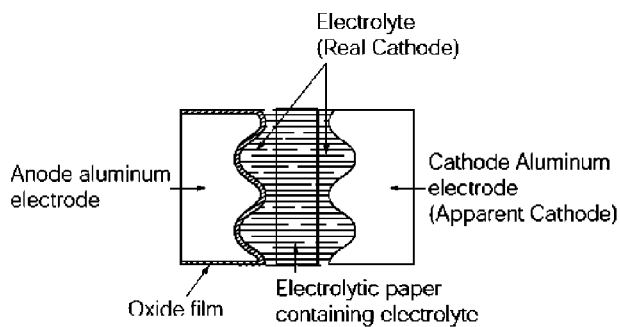

Fig. 1 - 1

Figure 16 (Nichicon Figure 1-1)

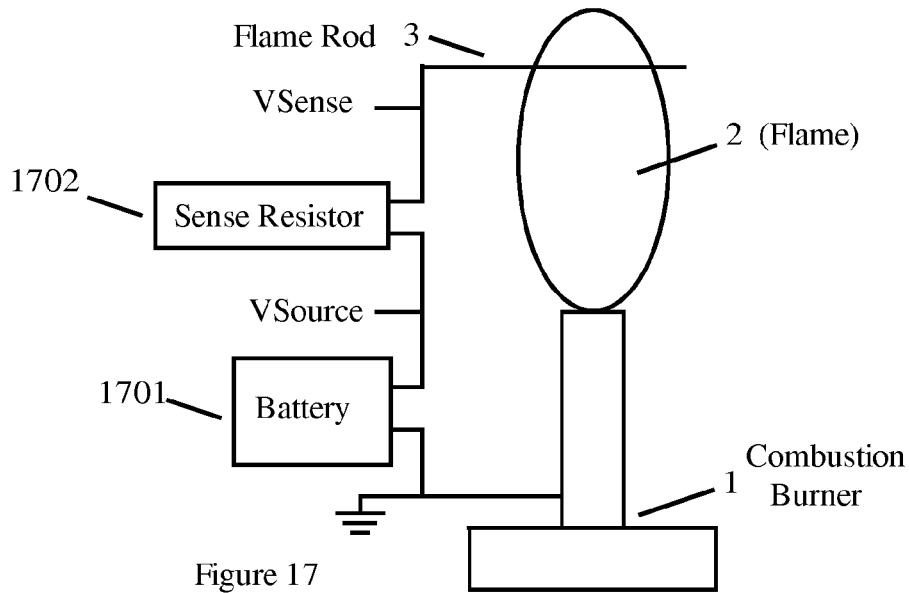

Figure 17

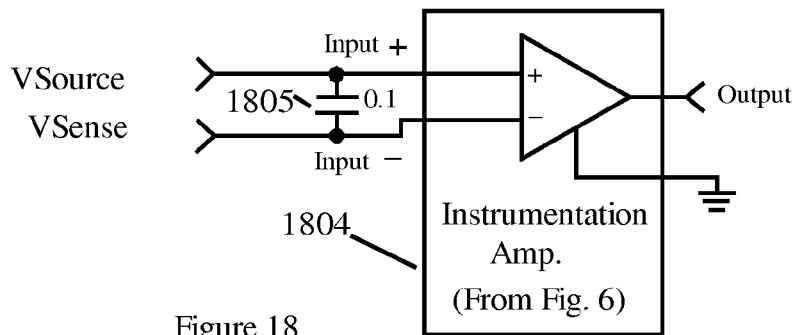
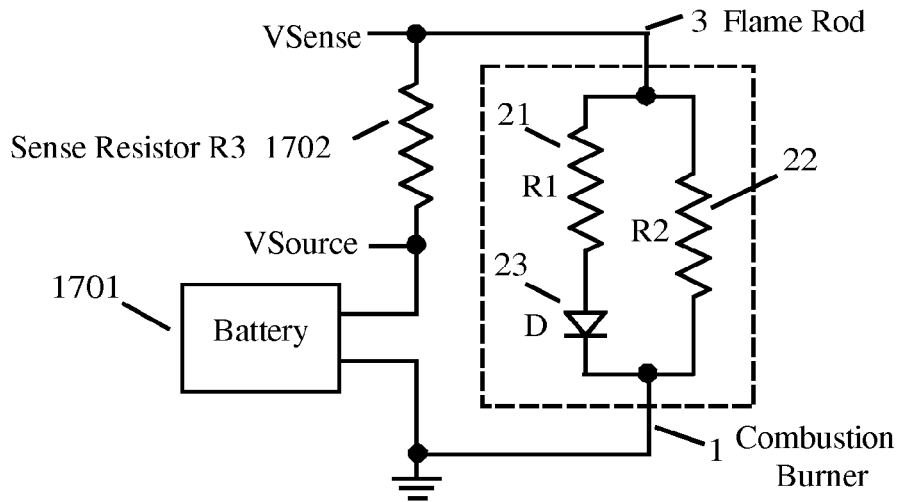
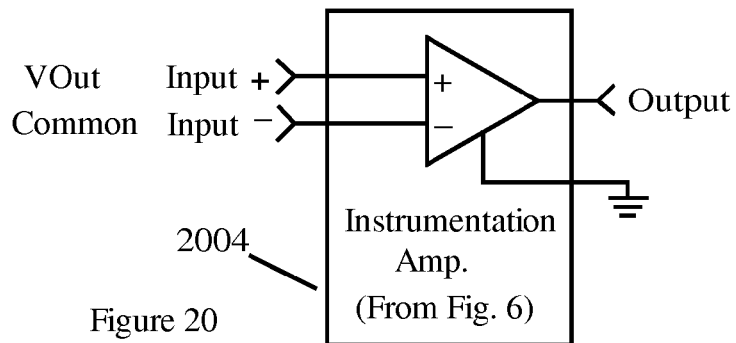
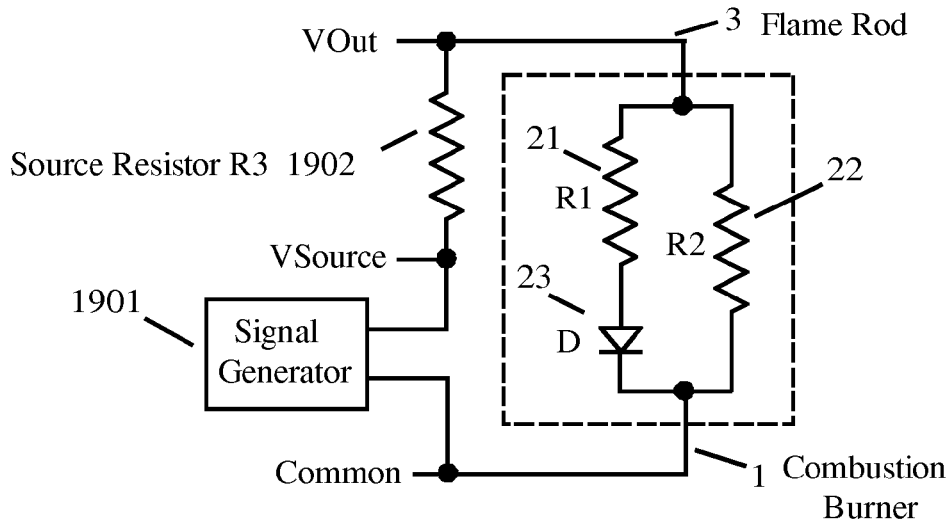
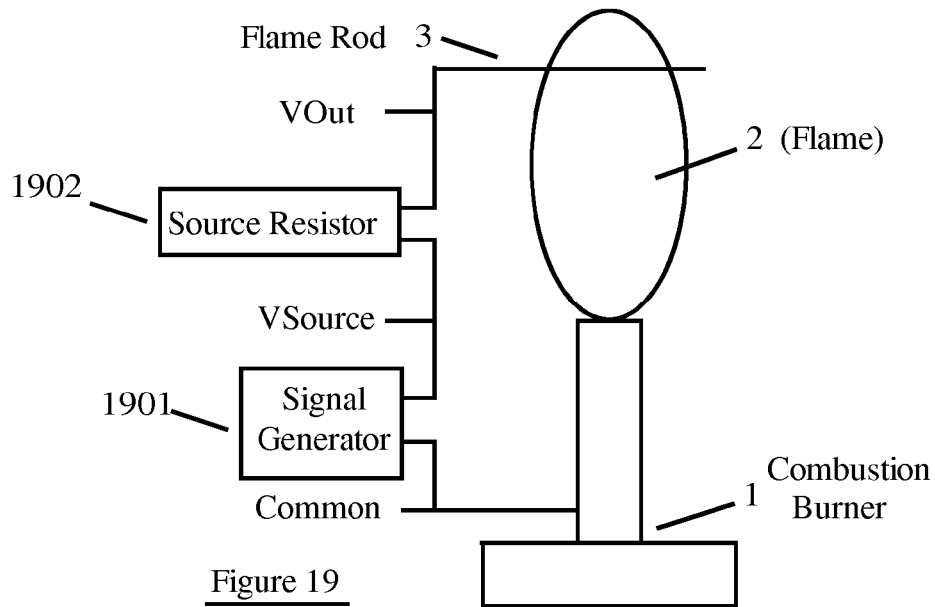

Figure 18



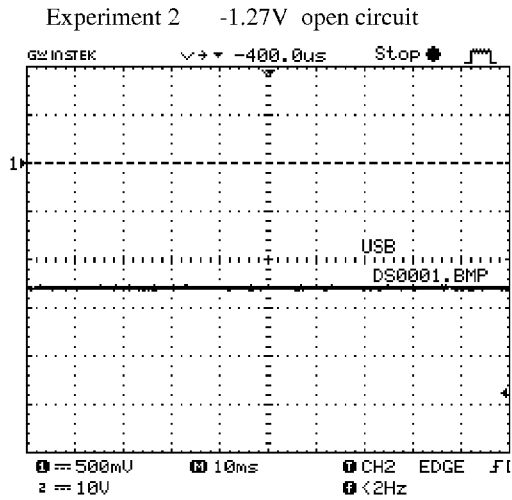

Figure 21a

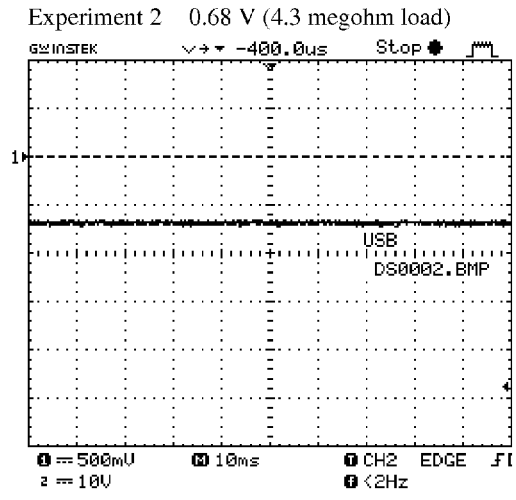

Figure 21b

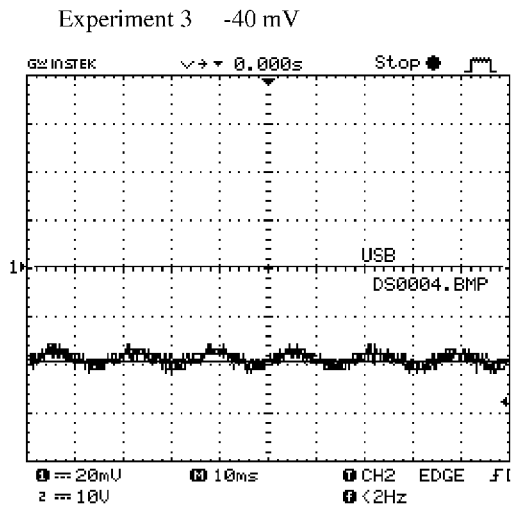

Figure 22a

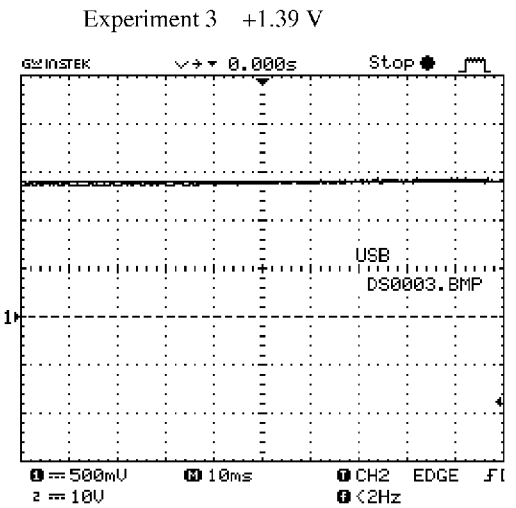

Figure 22b

Experiment 4 100 Hz +2.79 V to -7.2 V

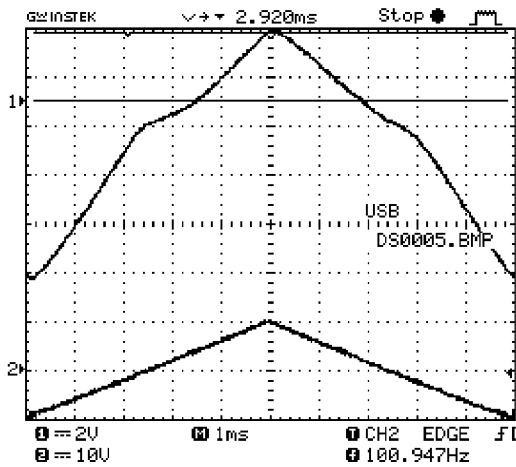

Figure 23a

Experiment 4 Leading Edge -960 mV to 0 V

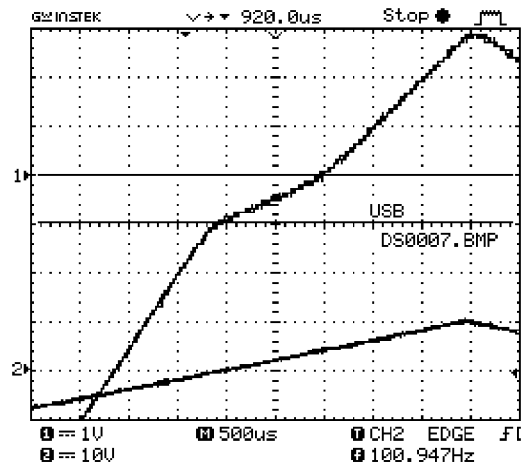

Figure 23b

Experiment 4 Trailing Edge -640 mV to -1.20 V

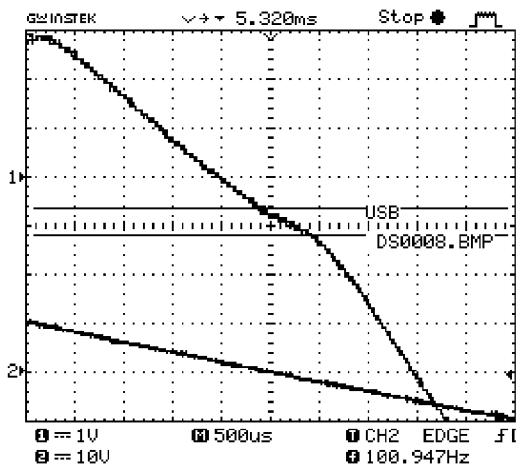

Figure 23c

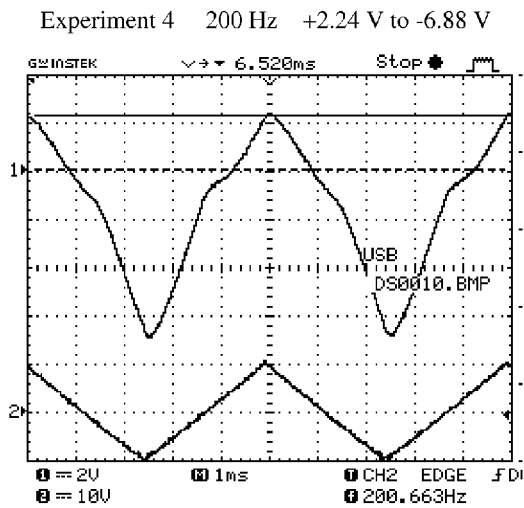

Figure 24a

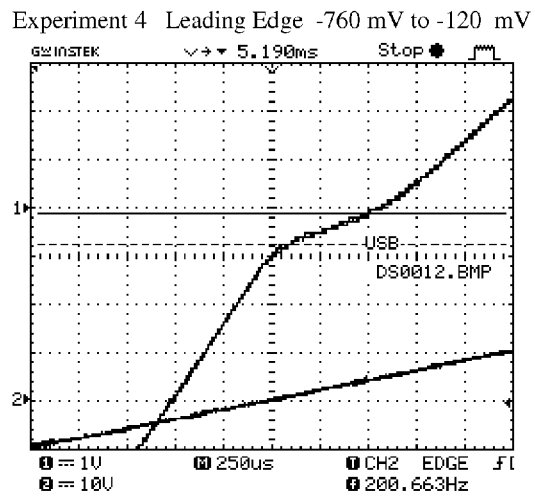

Figure 24b

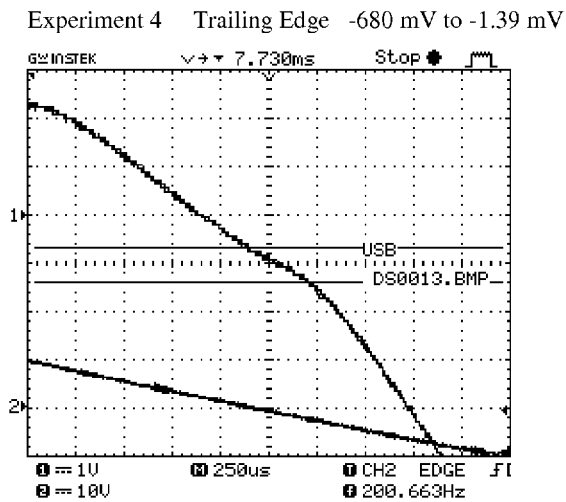

Figure 24c

Experiment 4 400 Hz +1.84 V to -6.32 V

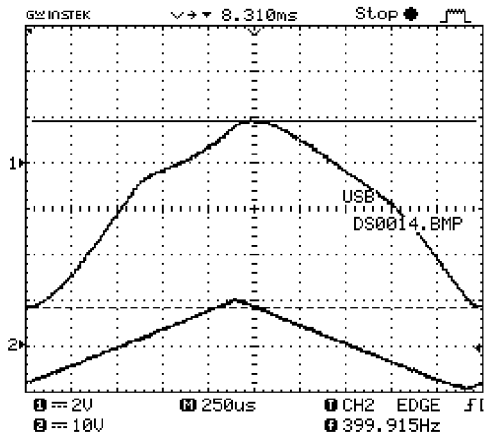

Figure 25a

Experiment 4 Leading Edge -440 mV to +200 mV

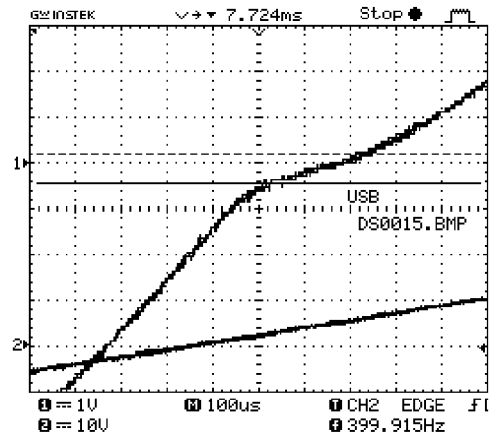

Figure 25b

Experiment 4 Trailing Edge -1.63 V to -2.0 V

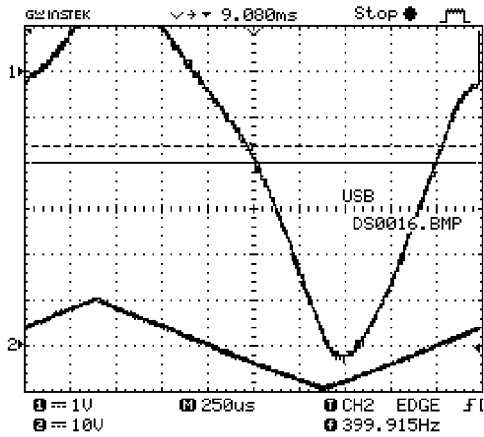

Figure 25c

Experiment 4 1KHz +0.920 V to -4.88 V

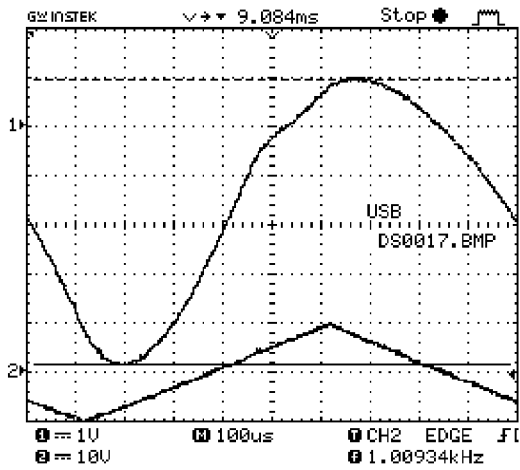

Figure 26a

Experiment 4 Leading Edge -340 mV to +440 mV

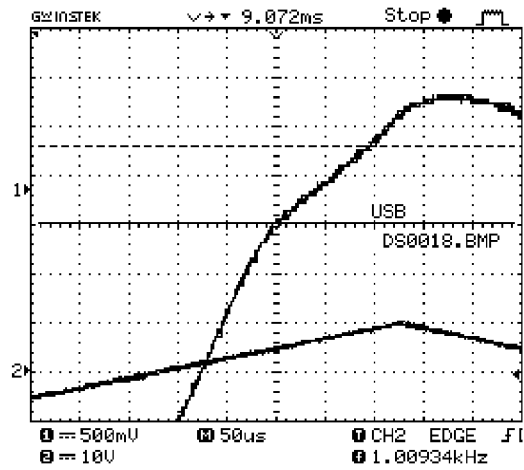

Figure 26b

Experiment 4 Trailing Edge - Indistinct

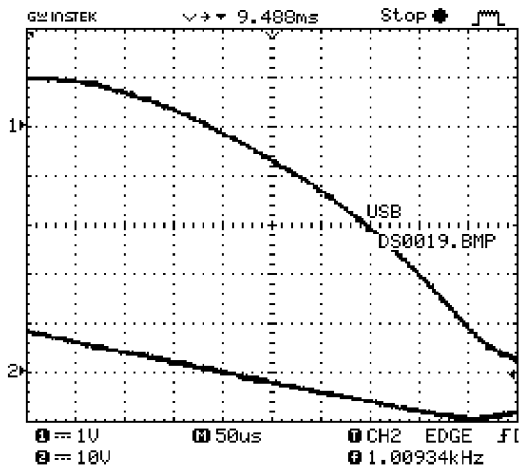

Figure 26c

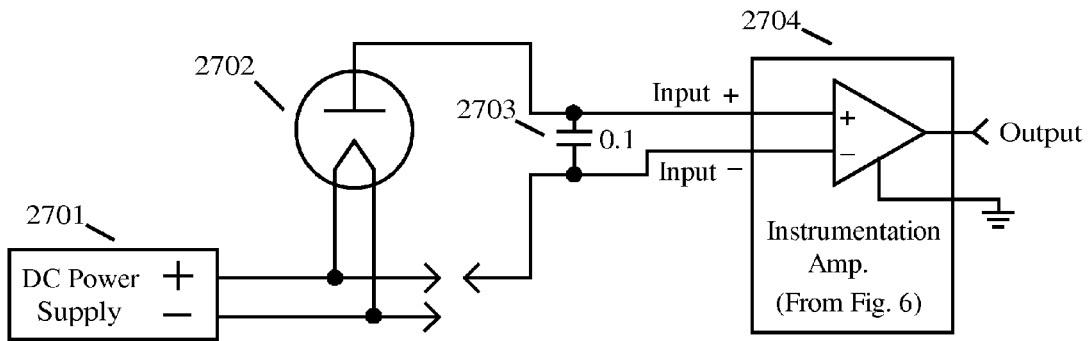

Figure 27

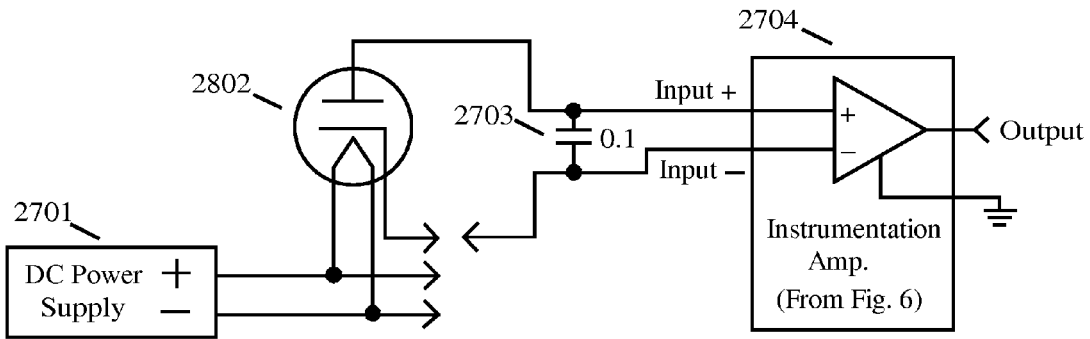

Figure 28

Table 4 - Thermionic Emission Test – 5U4GB Vacuum Tube

5U4GB	#1 Westinghouse	1/12/14		jm
2	Filament(2)		0V	+5 VDC 2.94A
8	Filament(8)		+5 VDC 2.93A	0V
2	Filament(2)		Ref	Ref
4	Plate 1		-0.93V	-3.46V
6	Plate 2		-0.01V	-5.59V
8	Filament(8)		Ref	Ref
4	Plate 1		-5.68V	-0.09V
6	Plate 2		-3.30V	-0.84V

Figure 29

Table 5 - Thermionic Emission Test – 5Y3 Vacuum Tube

5Y3	#1 RCA	1/12/2014		jm
2	Filament(2)		0V	+5 VDC 2.00A
8	Filament(8)		+5 VDC 1.98A	0V
2	Filament(2)		Ref	Ref
4	Plate 1		-0.61V	-3.04V
6	Plate 2		0.0V	-5.25V
8	Filament(8)		Ref	Ref
4	Plate 1		-5.37V	0.0V
6	Plate 2		-3.00V	-0.51V

Figure 30

Table 6 - Thermionic Emission Test – 6X4 Vacuum Tube

6X4 #1 Raytheon		1/13/14 jm			
3	Filament(3)	0V	3	Filament(3)	+6.3DC 0.60A
4	Filament(4)	+6.3VDC 0.59A	4	Filament(4)	0V
7	Cathode	Ref	7	Cathode	Ref
6	Plate 1	-0.91V	6	Plate 1	-0.92V
1	Plate 2	-1.14V	1	Plate 2	-1.17V
7,3	Cathode, Filament(3)	Ref	7,3	Cathode, Filament(3)	Ref
6	Plate 1	-0.91V	6	Plate 1	-0.93V
1	Plate 2	-1.16V	1	Plate 2	-1.18V
7,4	Cathode, Filament(4)	Ref	7,4	Cathode, Filament(4)	Ref
6	Plate 1	-0.91V	6	Plate 1	-0.93V
1	Plate 2	-1.16V	1	Plate 2	-1.19V
3	Filament(3)	Ref	3	Filament(3)	Ref
7	Cathode	+2.50V	7	Cathode	-3.67V
4	Filament(4)	Ref	4	Filament(4)	Ref
7	Cathode	-3.66V	7	Cathode	+2.52V

Figure 31

Table 7 - Thermionic Emission Test – 12X4 Vacuum Tube

12X4 #1 RCA			01/13/2014 jm		
3	Filament	0V	3	Filament	+12.6 VDC 0.32A
4	Filament	+12.6 VDC 0.32A	4	Filament	0V
7	Cathode	Ref	7	Cathode	Ref
6	Plate 1	-1.17V	6	Plate 1	-1.17V
1	Plate 2	-1.04V	1	Plate 2	-1.05V
7,3	Cathode, Filament(3)	Ref	7,3	Cathode, Filament(3)	Ref
6	Plate 1	-1.17V	6	Plate 1	-1.17V
1	Plate 2	-1.04V	1	Plate 2	-1.05V
7,4	Cathode, Filament(4)	Ref	7,4	Cathode, Filament(4)	Ref
6	Plate 1	-1.17V	6	Plate 1	-1.17V
1	Plate 2	-1.05V	1	Plate 2	-1.05V
3	Filament(3)	Ref	3	Filament(3)	Ref
7	Cathode	+1.66V	7	Cathode	-4.70V
4	Filament(4)	Ref	4	Filament(4)	Ref
7	Cathode	-4.70V	7	Cathode	+1.83V

Figure 32

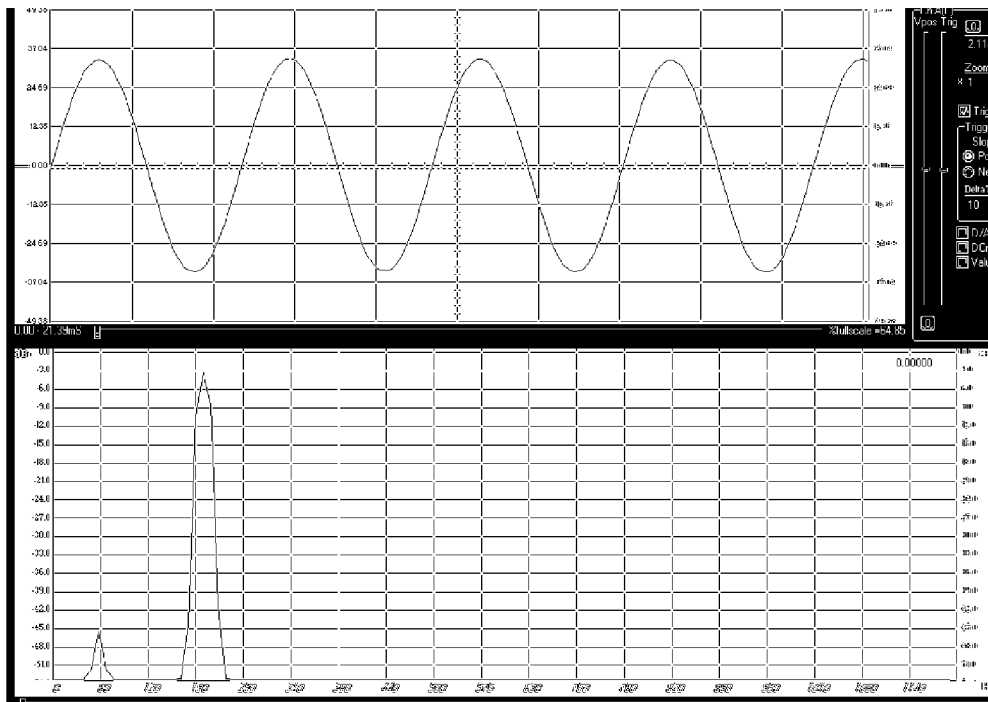

Figure 33a 200 Hz; 10 Megohm Source; Sine Wave; No Flame

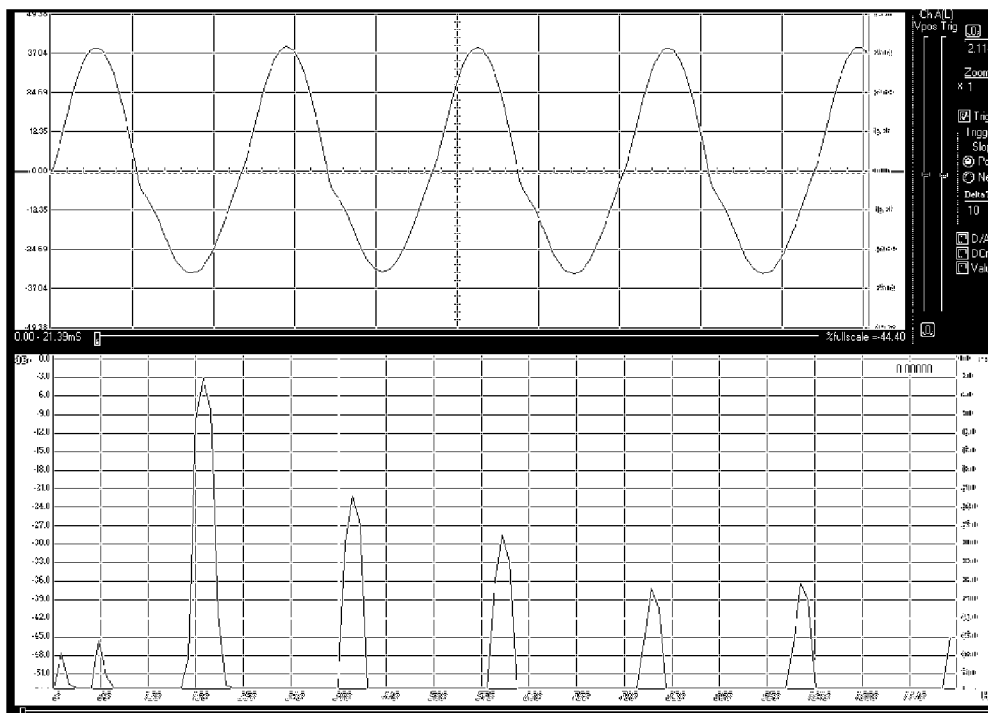

Figure 33b 200 Hz; 10 Megohm Source; Sine Wave; Flame

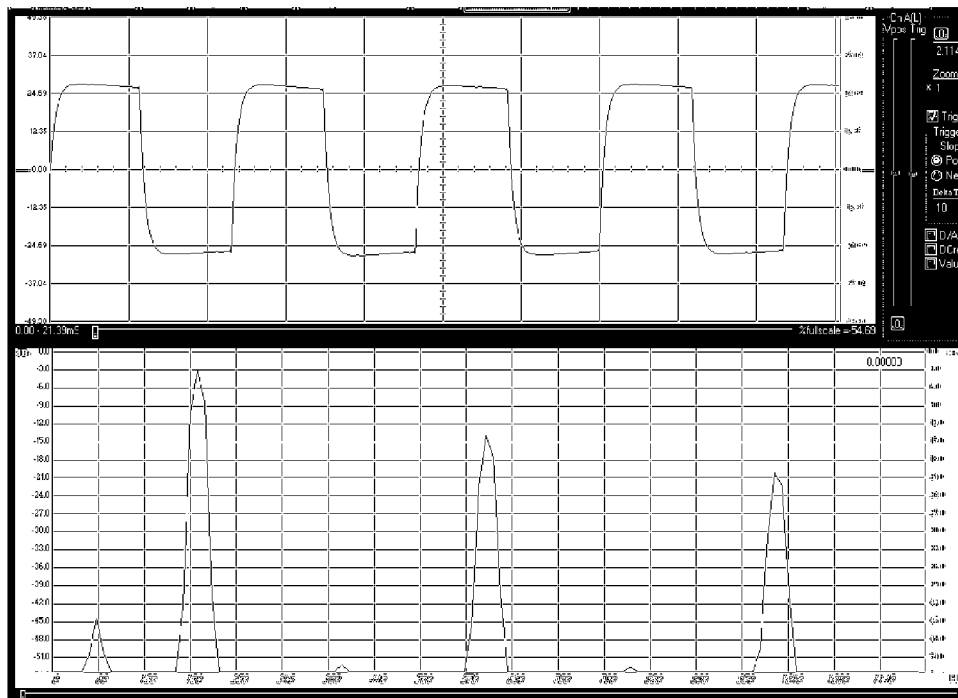

Figure 34a 200 Hz; 10 Megohm Source; Square Wave; No Flame

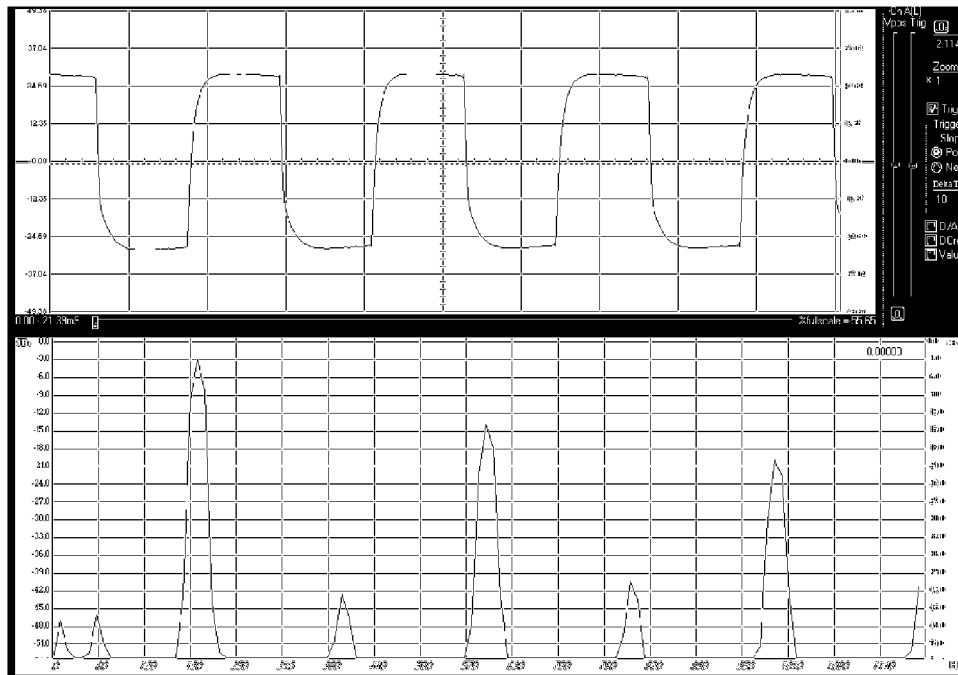

Figure 34b 200 Hz; 10 Megohm Source; Square Wave; Flame

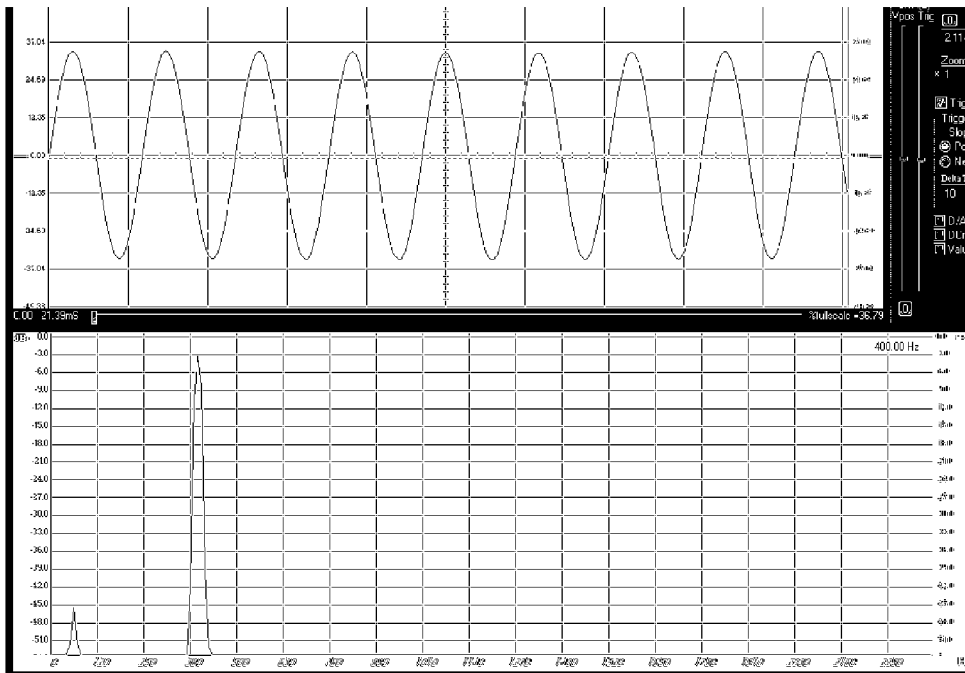

Figure 35a 400 Hz; 10 Megohm Source; Sine Wave; No Flame

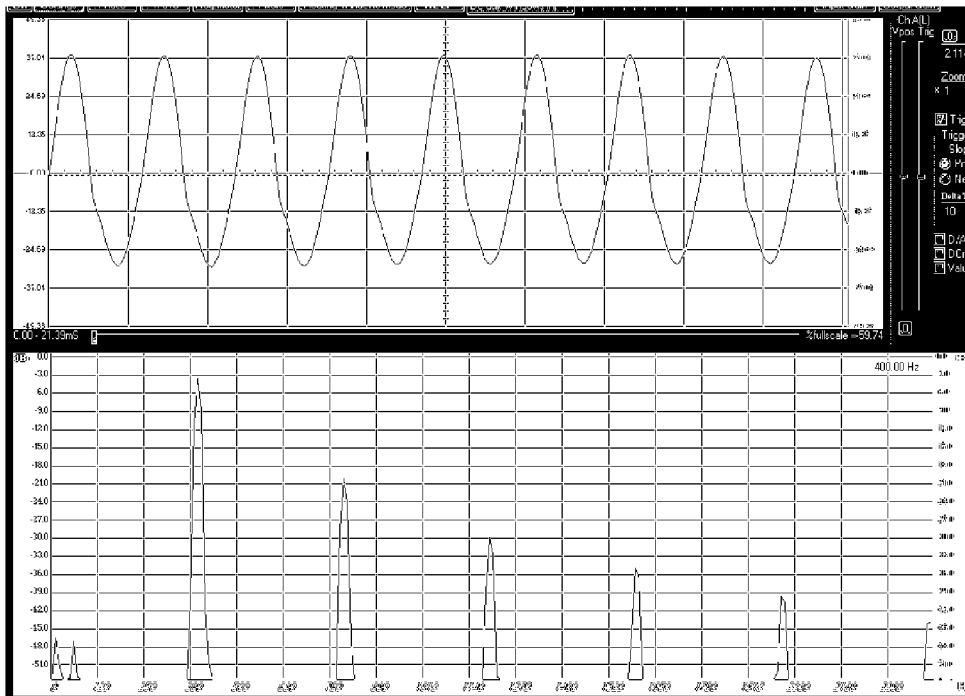

Figure 35b 400 Hz; 10 Megohm Source; Sine Wave; Flame

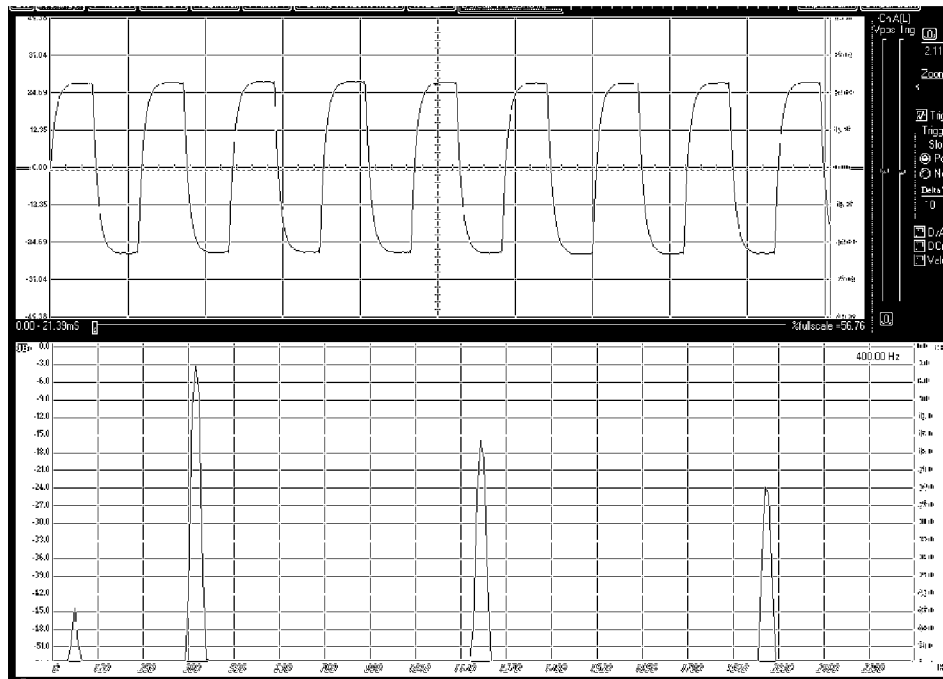

Figure 36a 400 Hz; 10 Megohm Source; Square Wave; No Flame

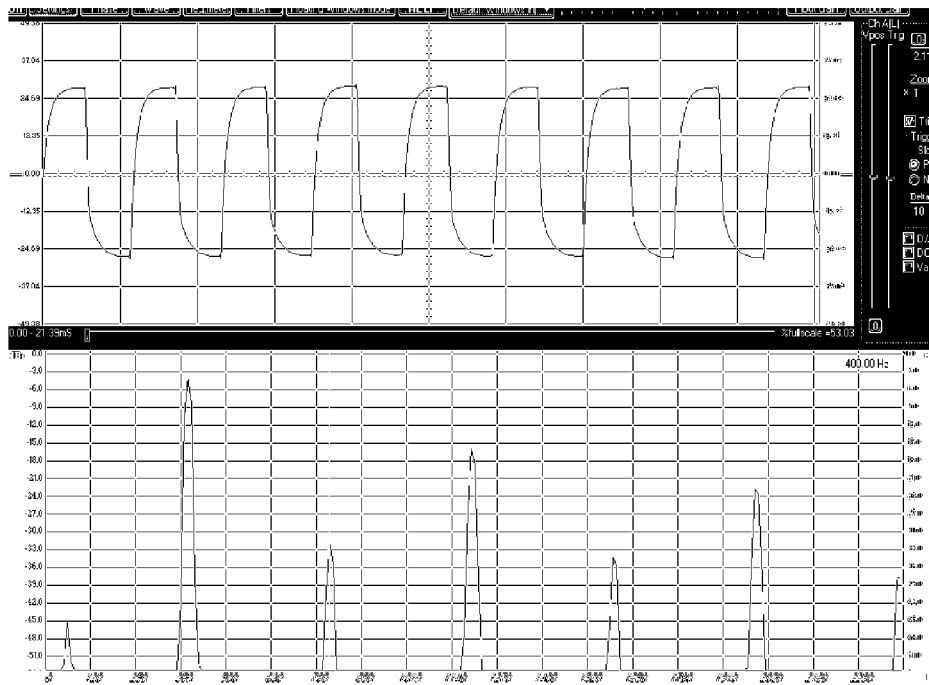

Figure 36b 400 Hz; 10 Megohm Source; Square Wave; Flame

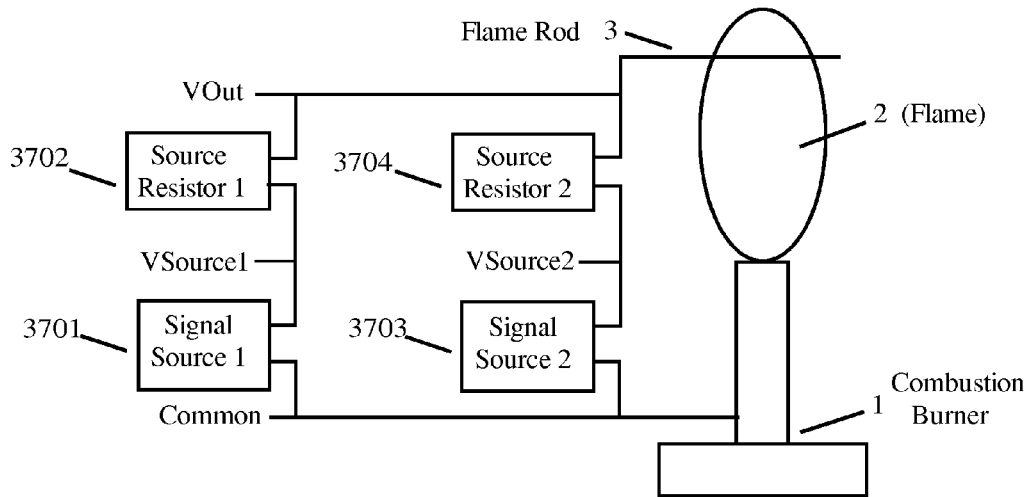

Figure 37

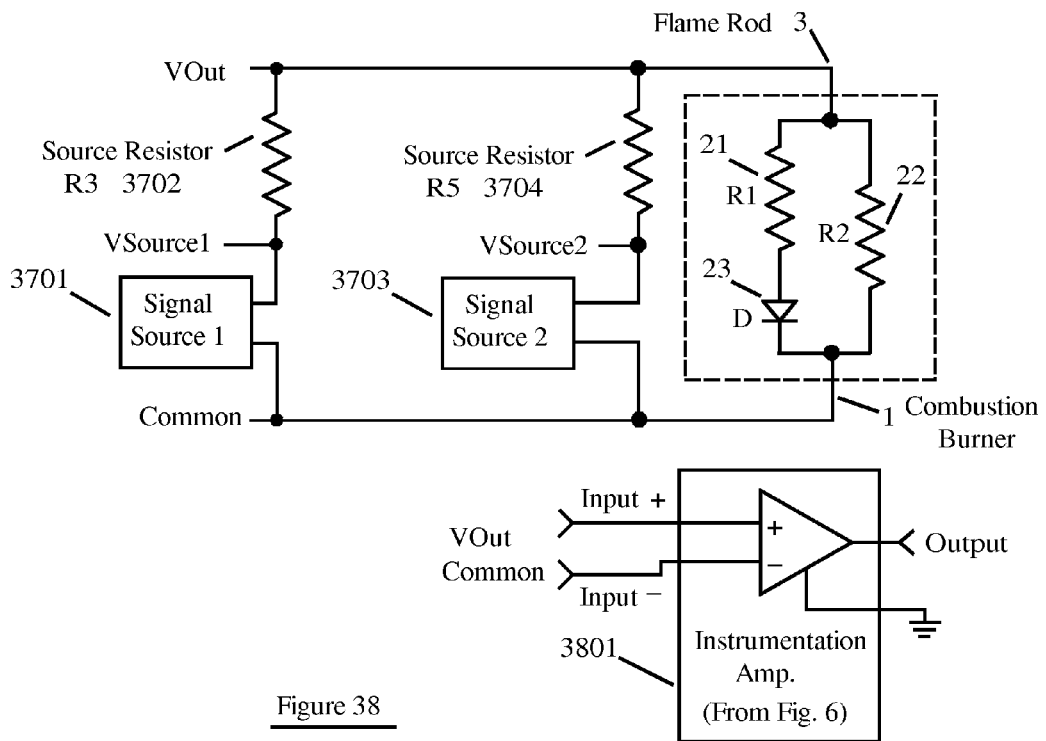

Figure 38

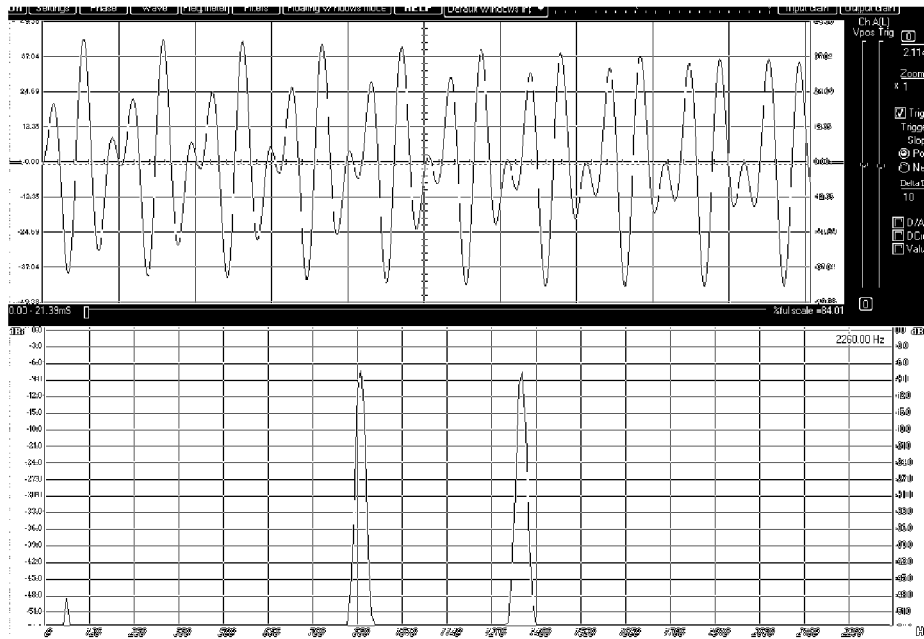
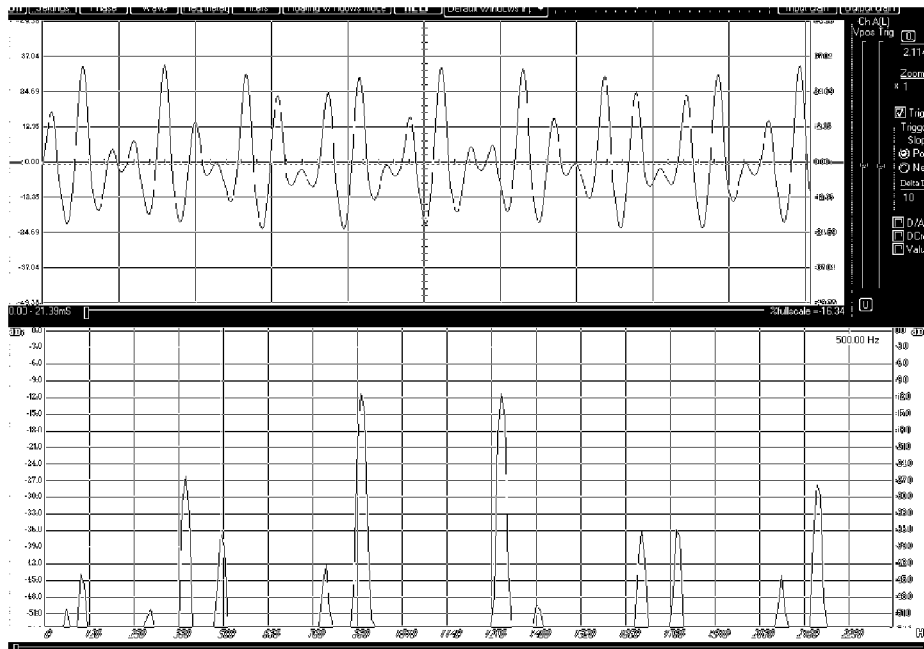
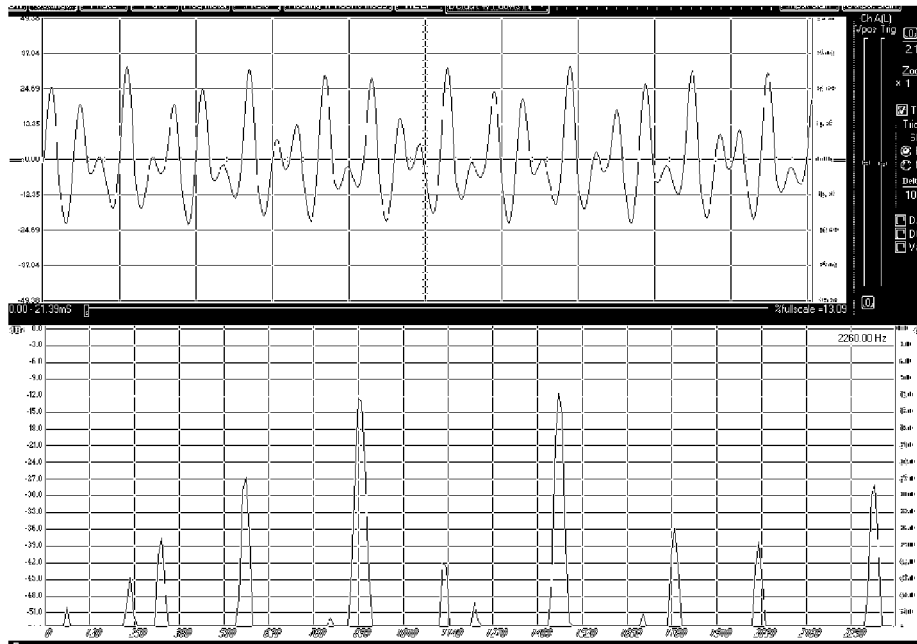

Figure 39a Mixer Test; Sine Waves (No Flame): 900 Hz (-7 dB); 1,300 Hz (-7 dB)



900 Hz (-12 dB); 1,300 Hz (-12 dB); 400 Hz (-27 dB); 2,200 Hz (-27 dB); 500 Hz (-39 dB)

Figure 39b Mixer Test; Sine Waves (Flame):



900 Hz (-12dB); 1,460 Hz (-12 dB); 560 Hz (-27 dB); 2,360 Hz (-28 dB); 340 Hz (-37 dB)

Figure 40 Mixer Test; Sine Waves (Flame)

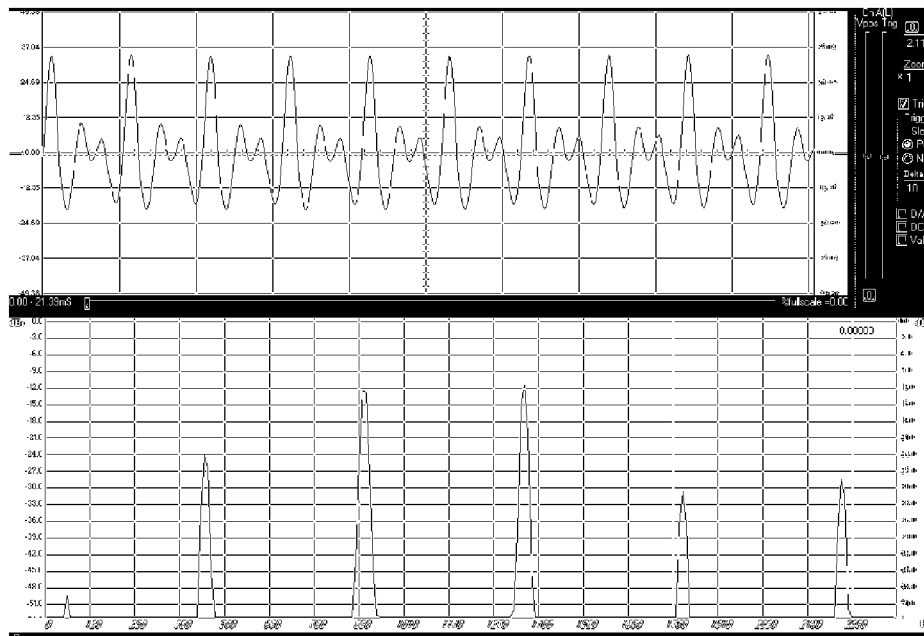

900 Hz (-12dB); 1,350 Hz (-12 dB); 450 Hz (-24 dB); 1,810 Hz (-32 dB); 2,260 Hz (-28 dB)

Figure 41 Mixer Test; Sine Waves (Flame)

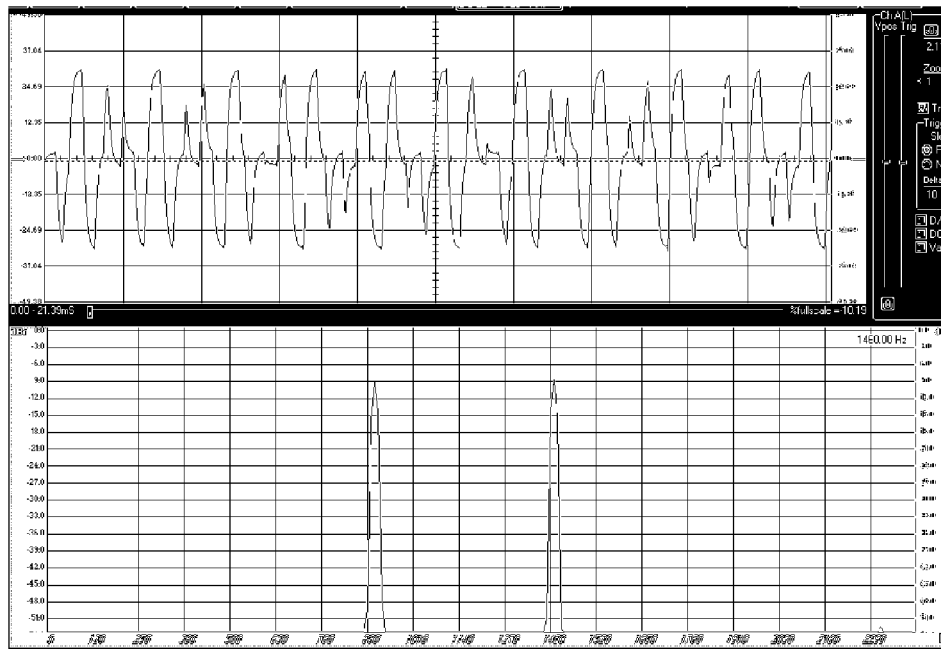

910 Hz (-9 dB); 1,410 Hz (-9 dB)

Figure 42a Mixer Test; Square Waves (No Flame)

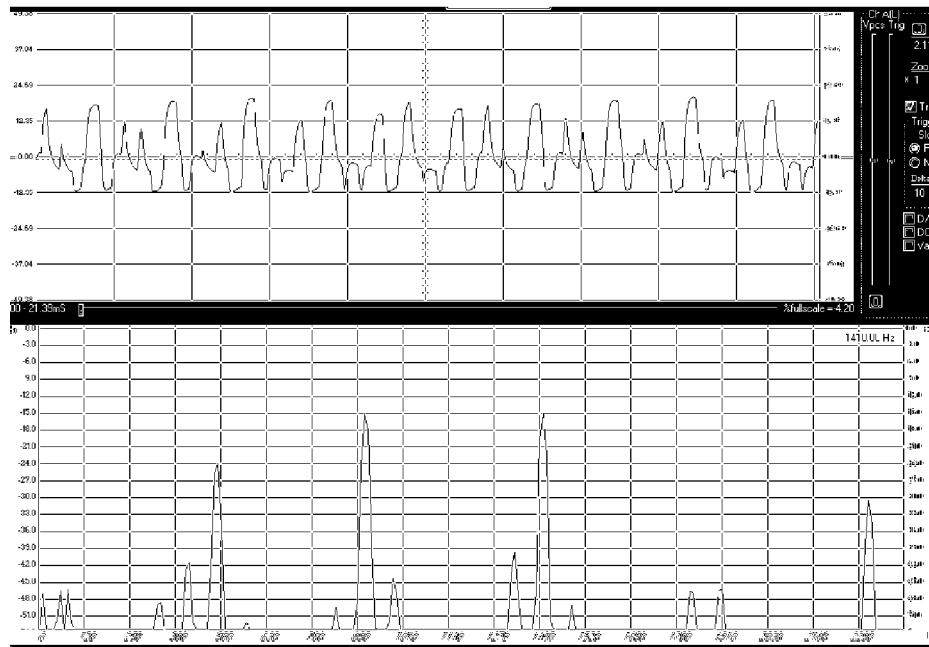

910 Hz (-15 dB); 1410 Hz (-15 dB); 500 Hz (-24 dB); 2,320 (-30 dB); 410 Hz (-41 dB)

Figure 42b Mixer Test; Square Waves (Flame)

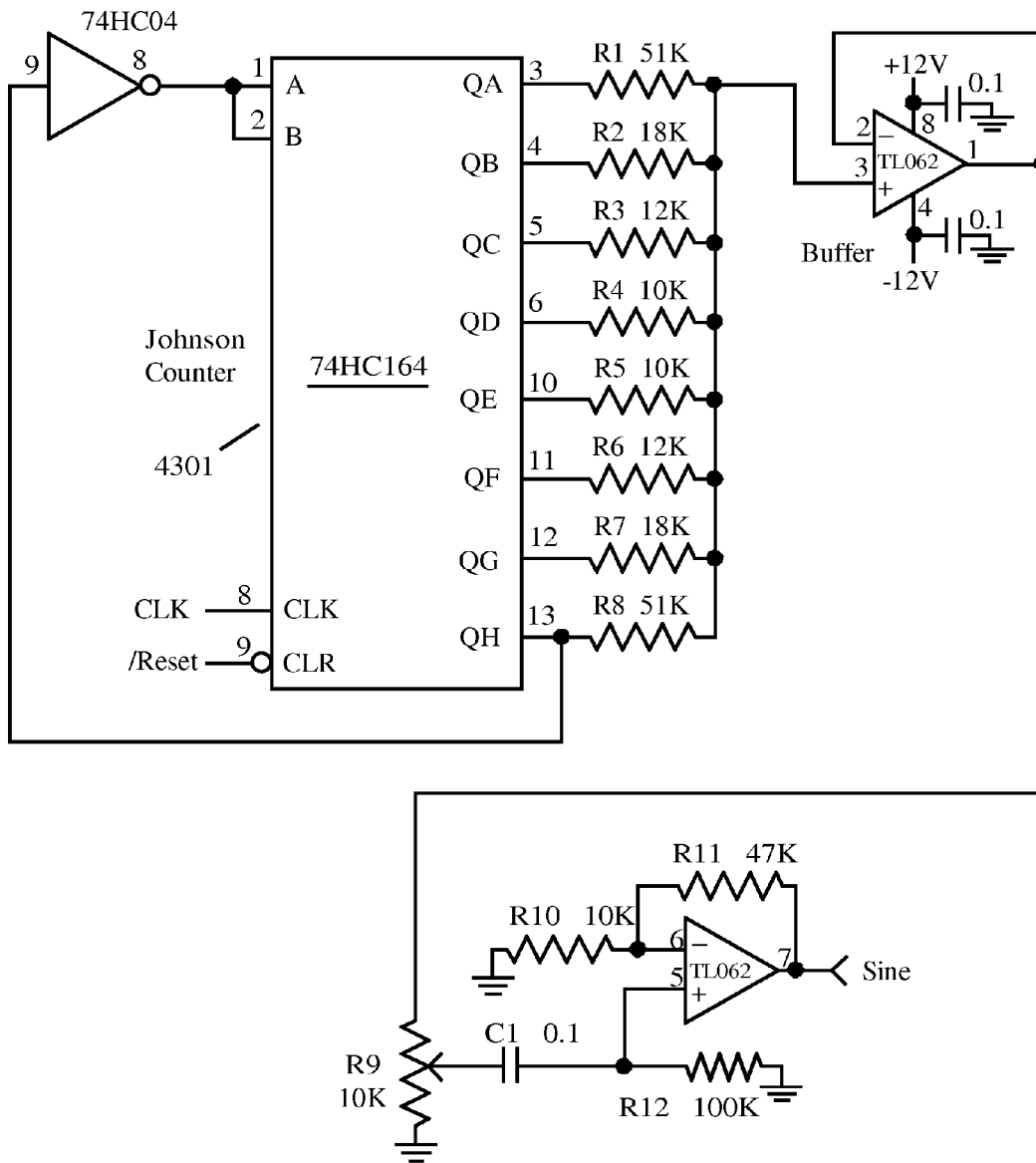

Figure 43a Sine Wave Generator

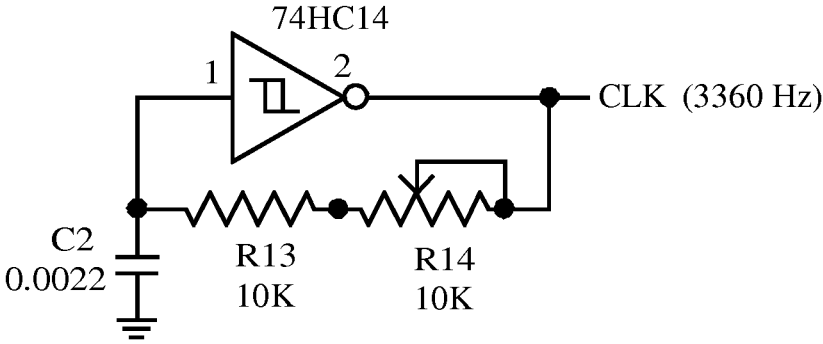

Figure 43b Oscillator

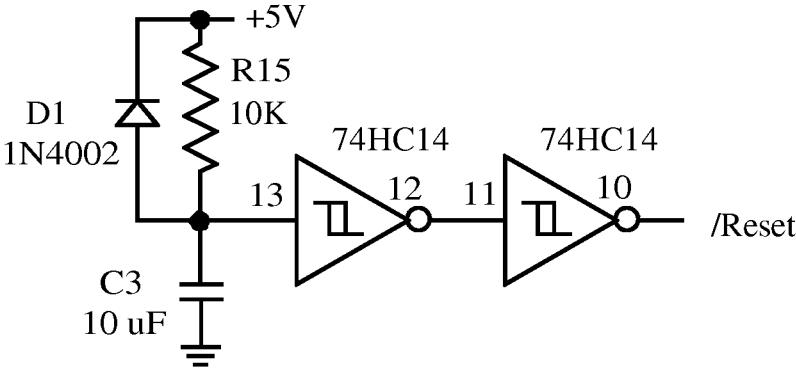
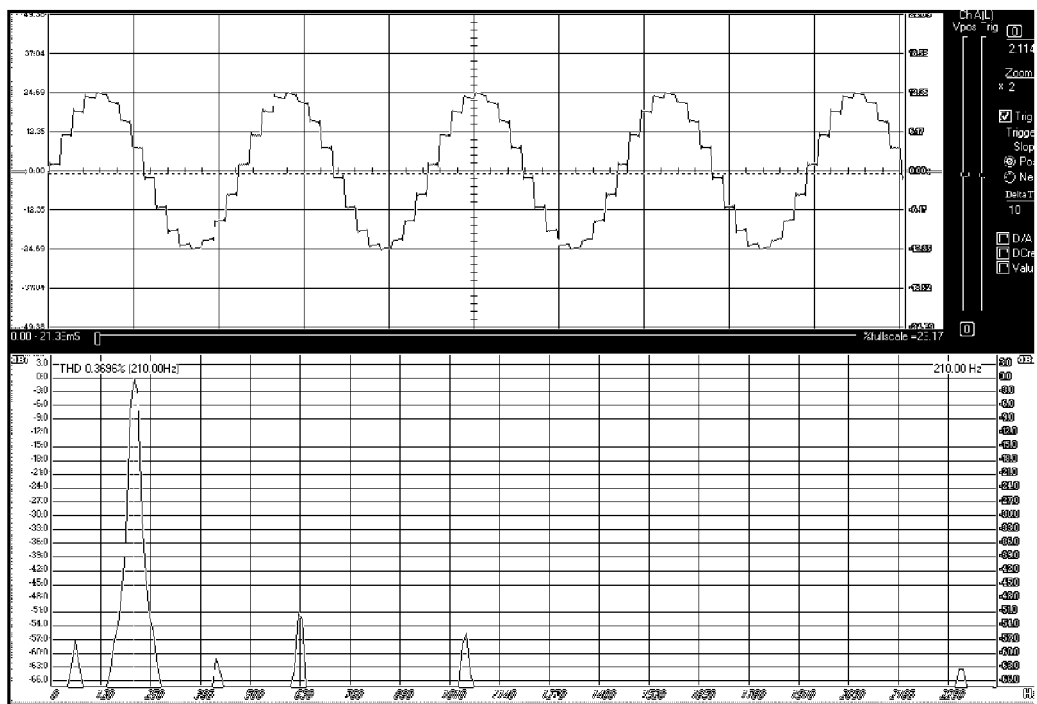
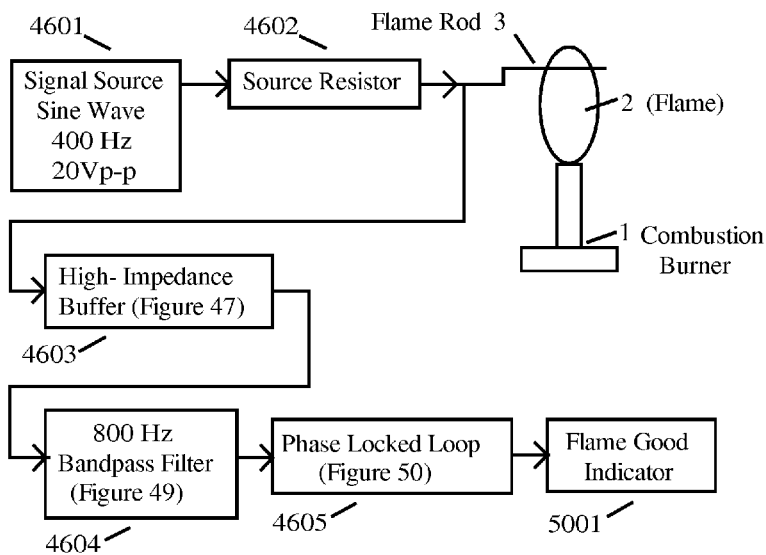
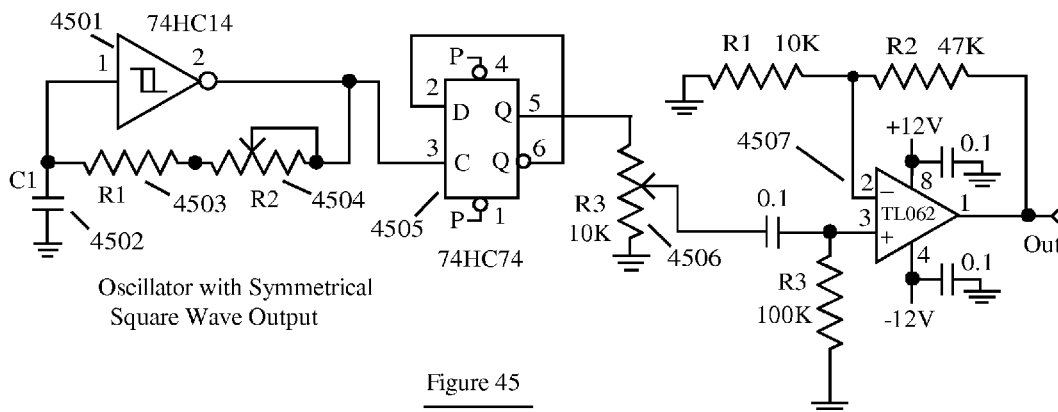

Figure 43c Reset



210 Hz Fundamental 0 dB; 2nd Harmonic -61 dB; 3rd Harmonic -51 dB;
5th Harmonic -54 dB; 60 Hz -57 dB

Figure 44 - Johnson Counter Results



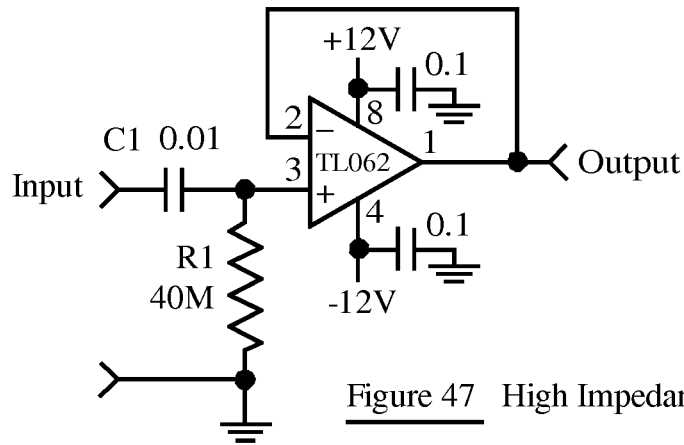

Figure 47 High Impedance Buffer

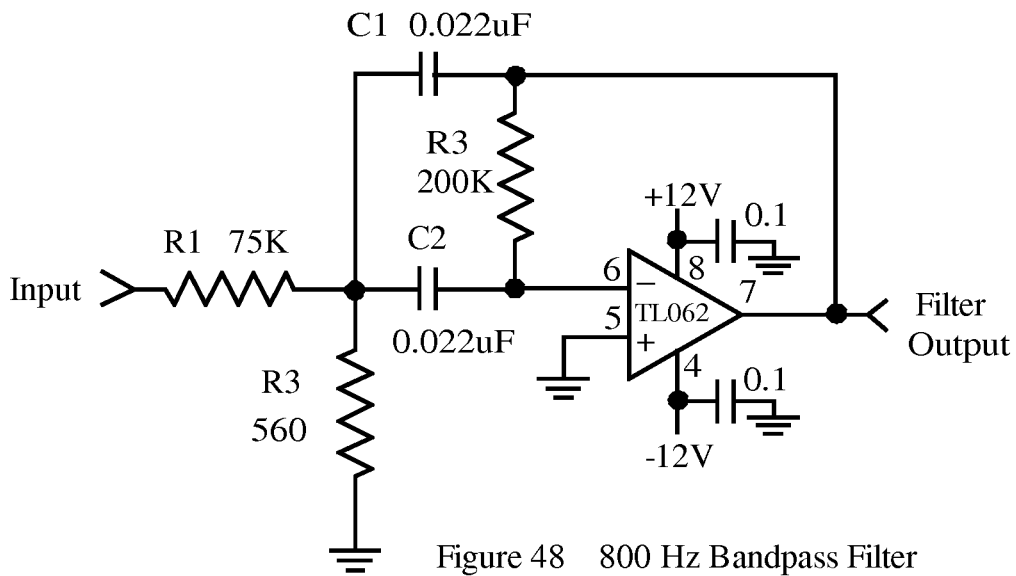

Figure 48 800 Hz Bandpass Filter

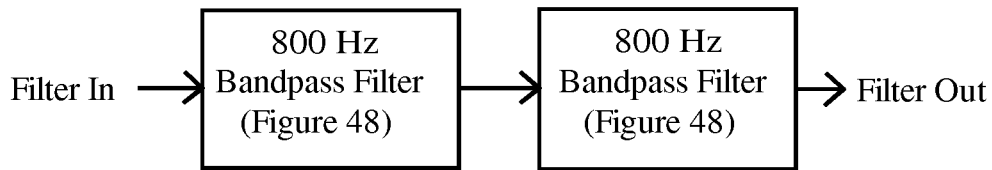

Figure 49 Two Cascaded Bandpass Filters

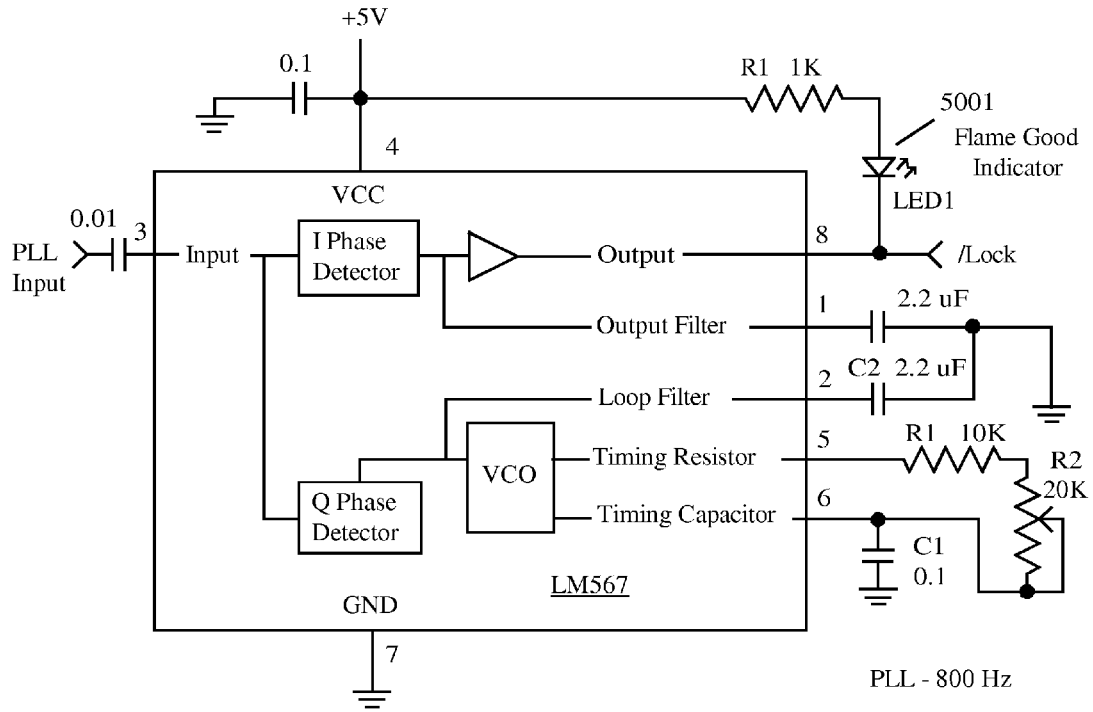

Figure 50

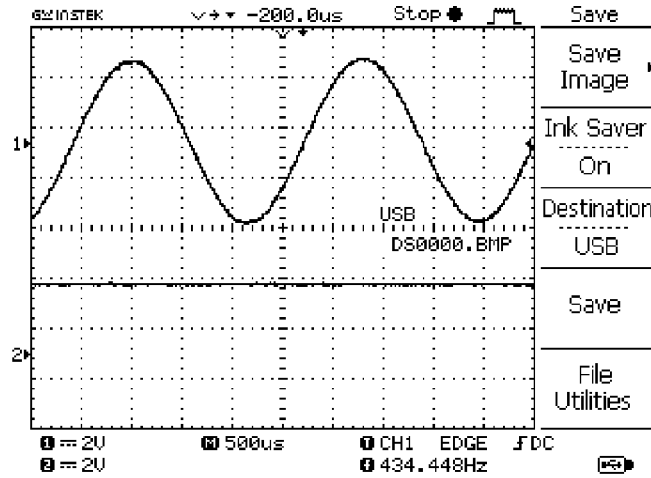

Figure 51a Sine Wave; 435 Hz; Flame Off

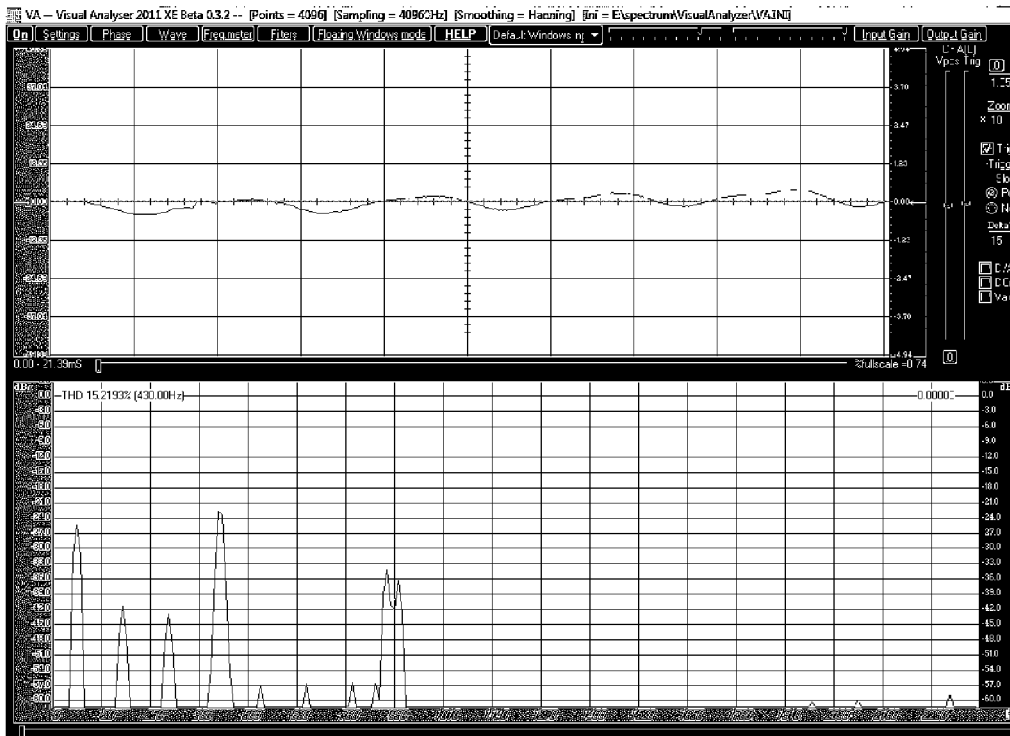

Figure 51b Sine Wave; 435 Hz; Flame Off

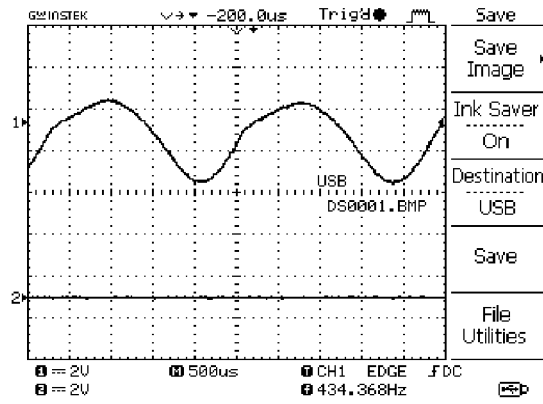

Figure 52a Sine Wave; 435 Hz; Flame On

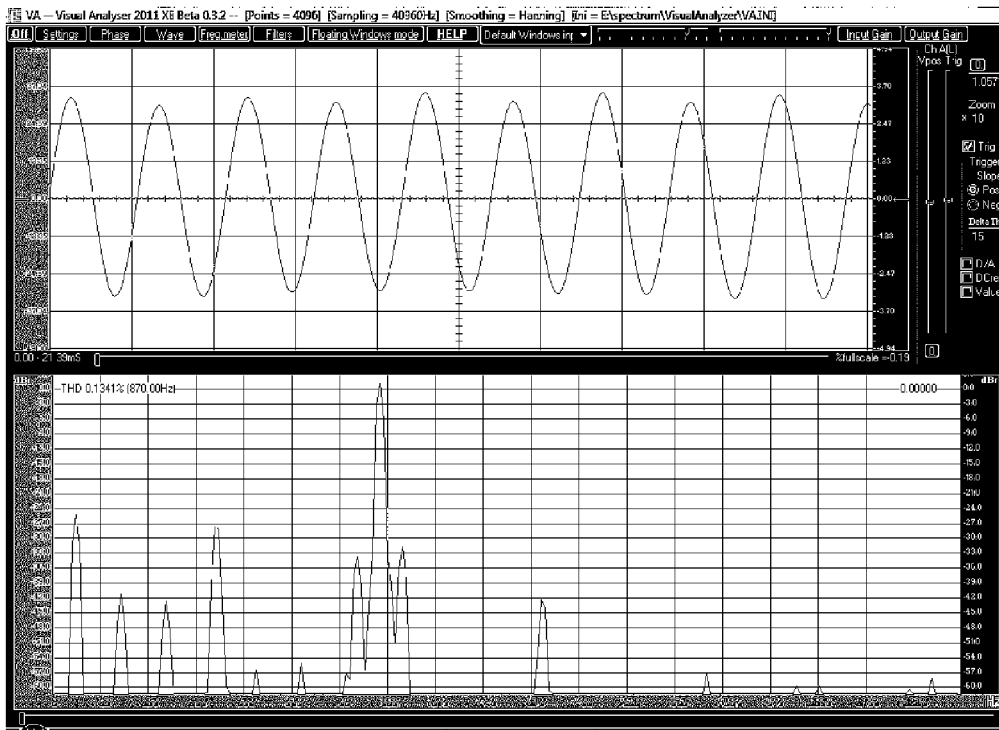

Figure 52b Sine 435 Hz; Flame On

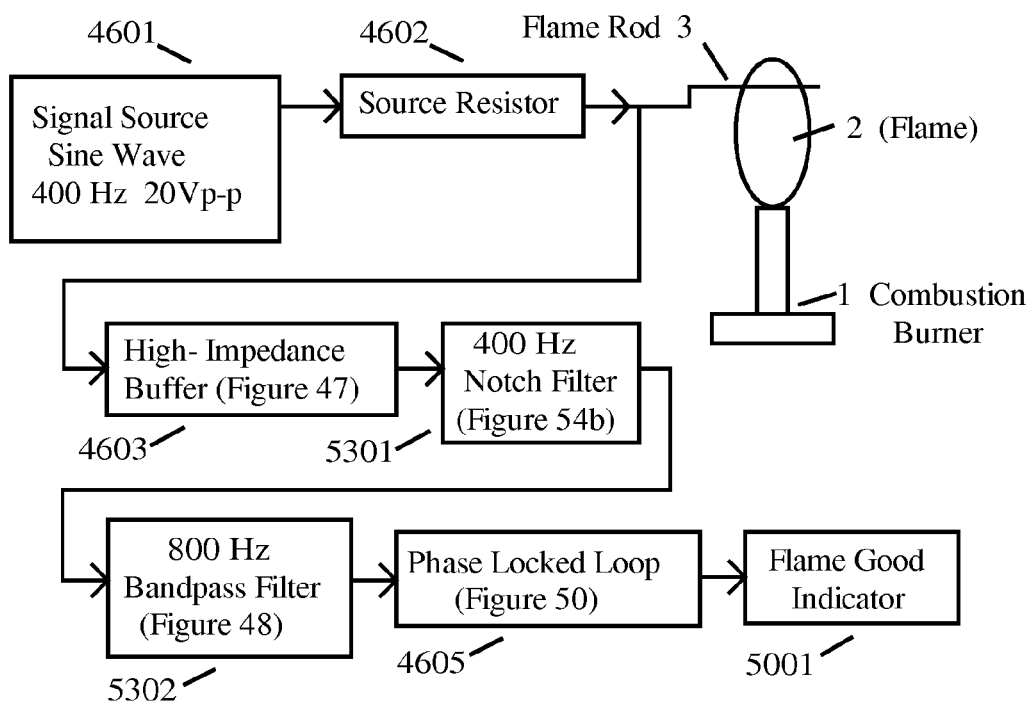

Figure 53

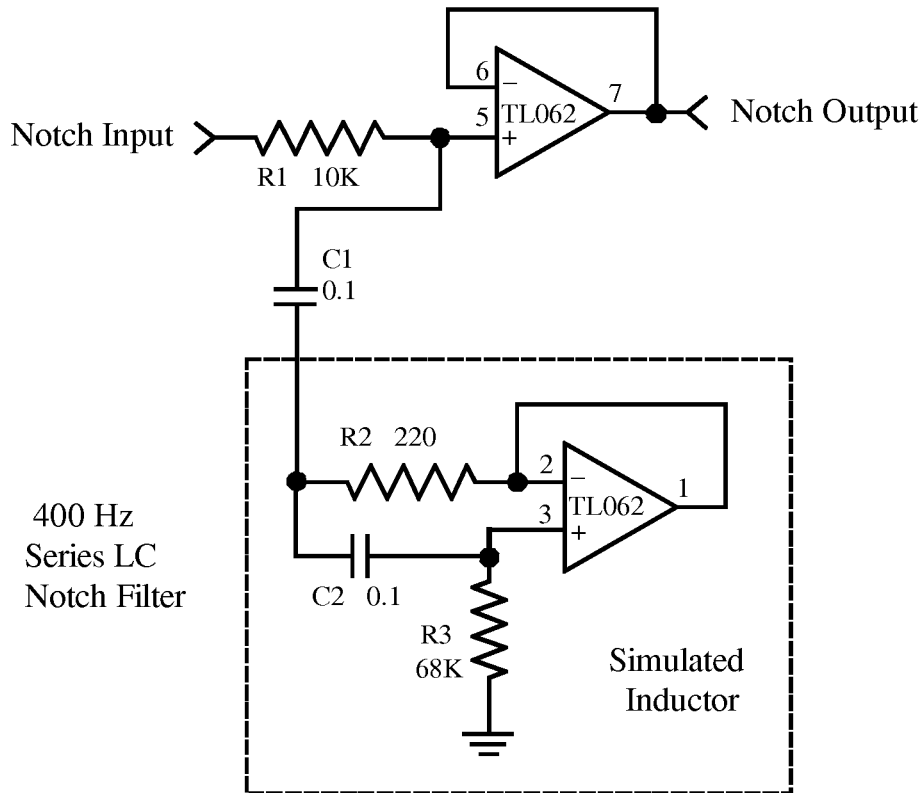
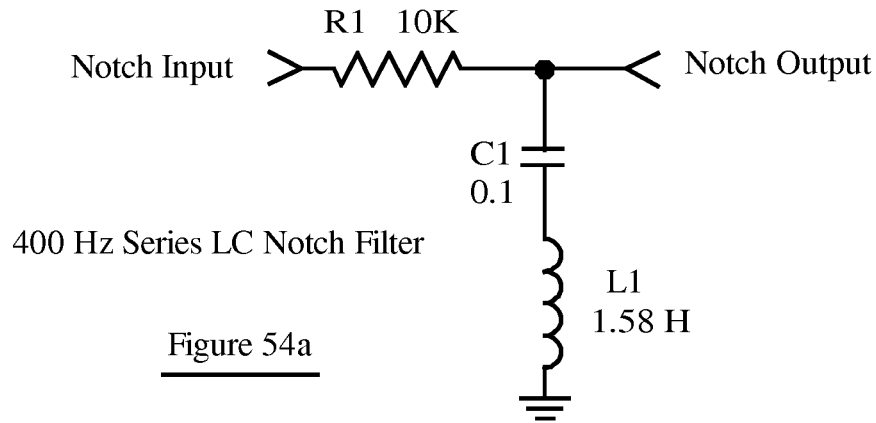

Figure 54b

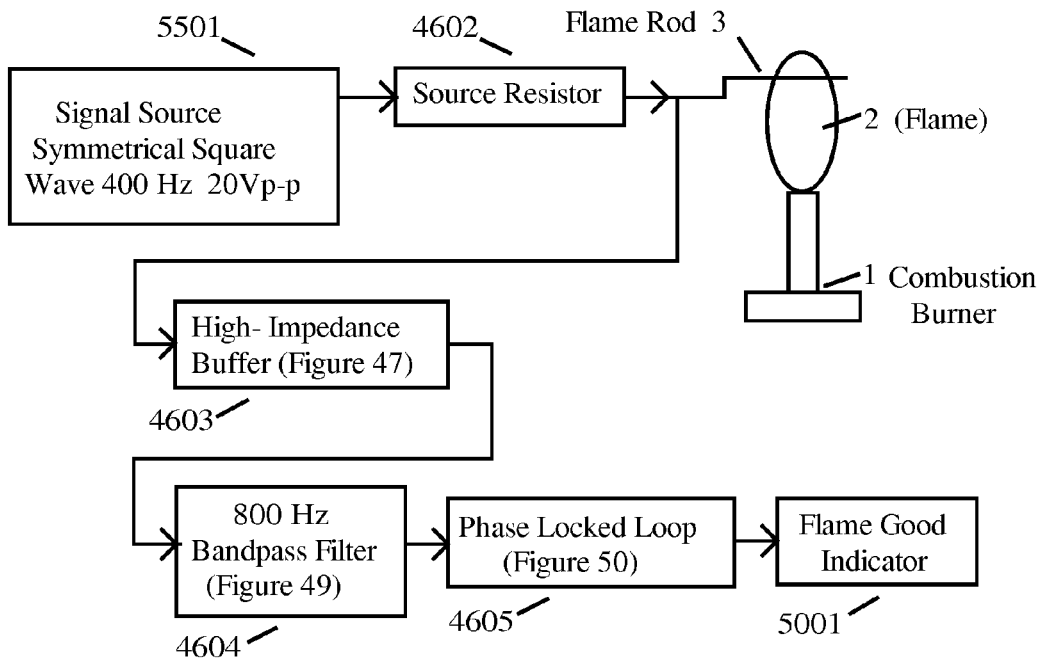

Figure 55

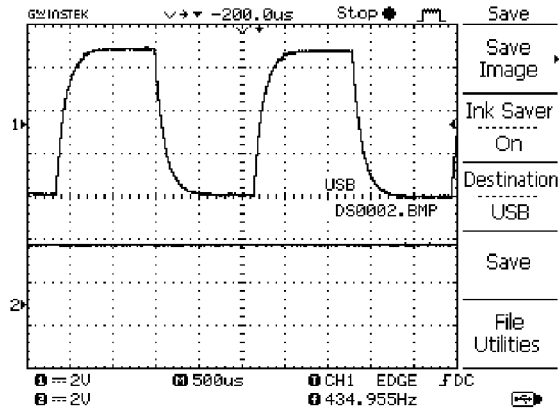

Figure 56a Square Wave; 435 Hz; Flame Off

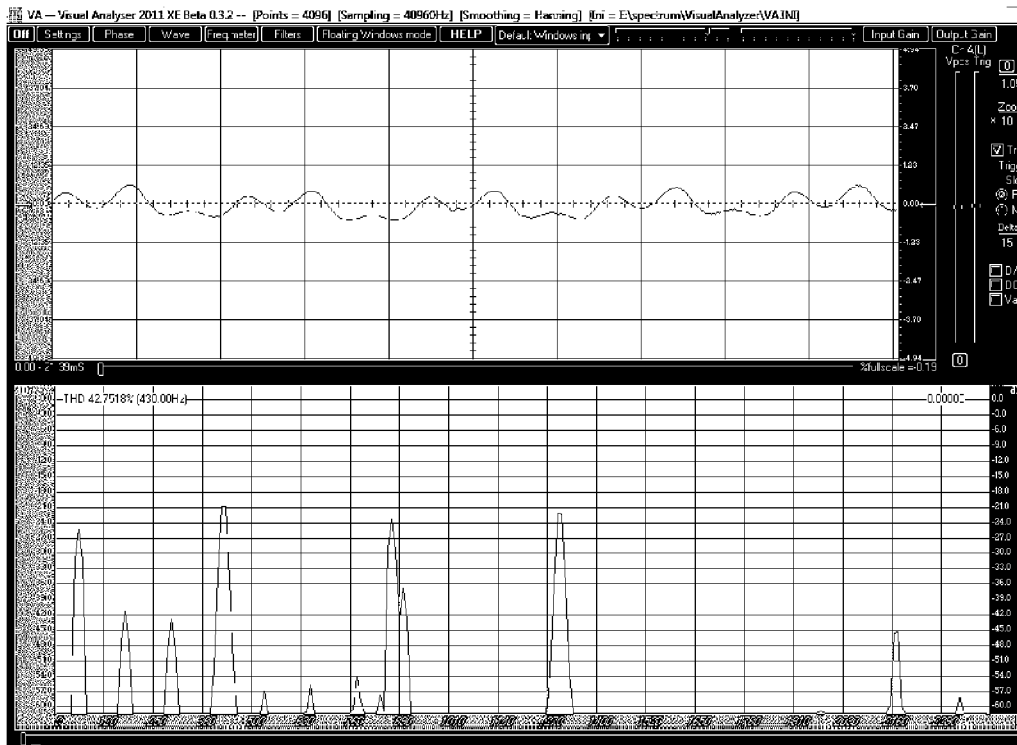

Figure 56b Square Wave; 435 Hz; Flame Off

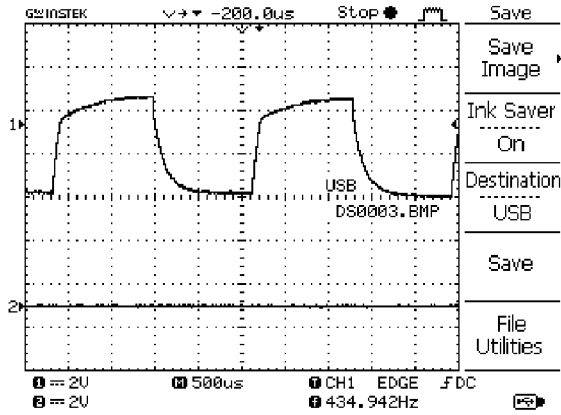

Figure 57a Square Wave; 435 Hz; Flame On

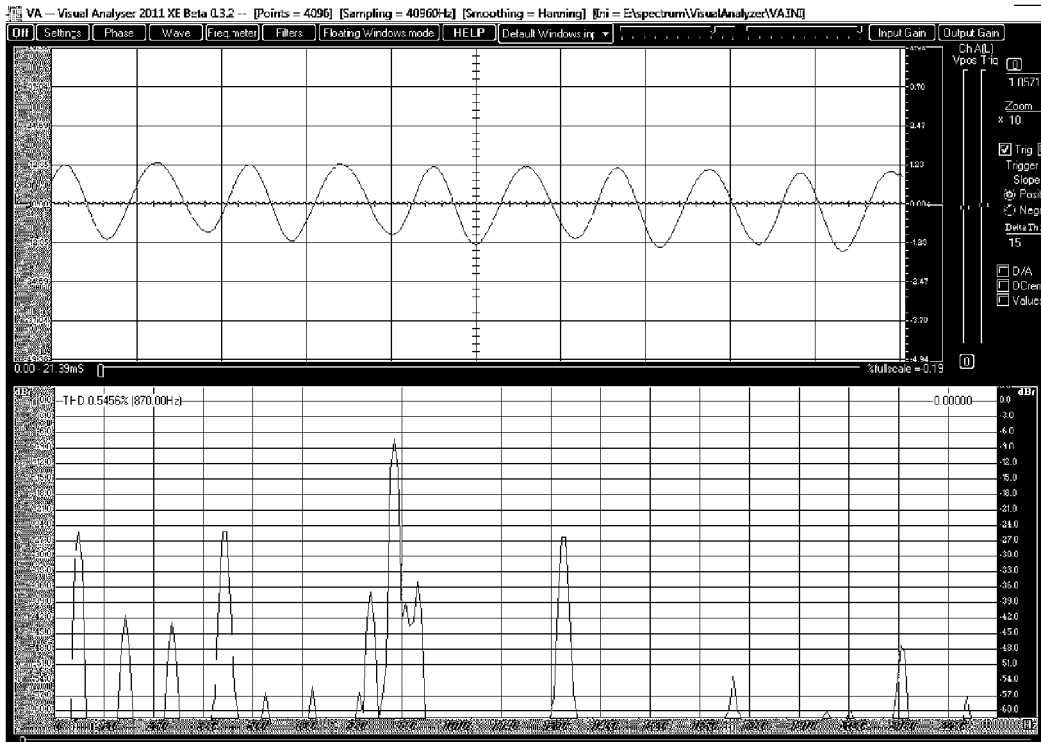

Figure 57b Square Wave; 435 Hz; Flame On

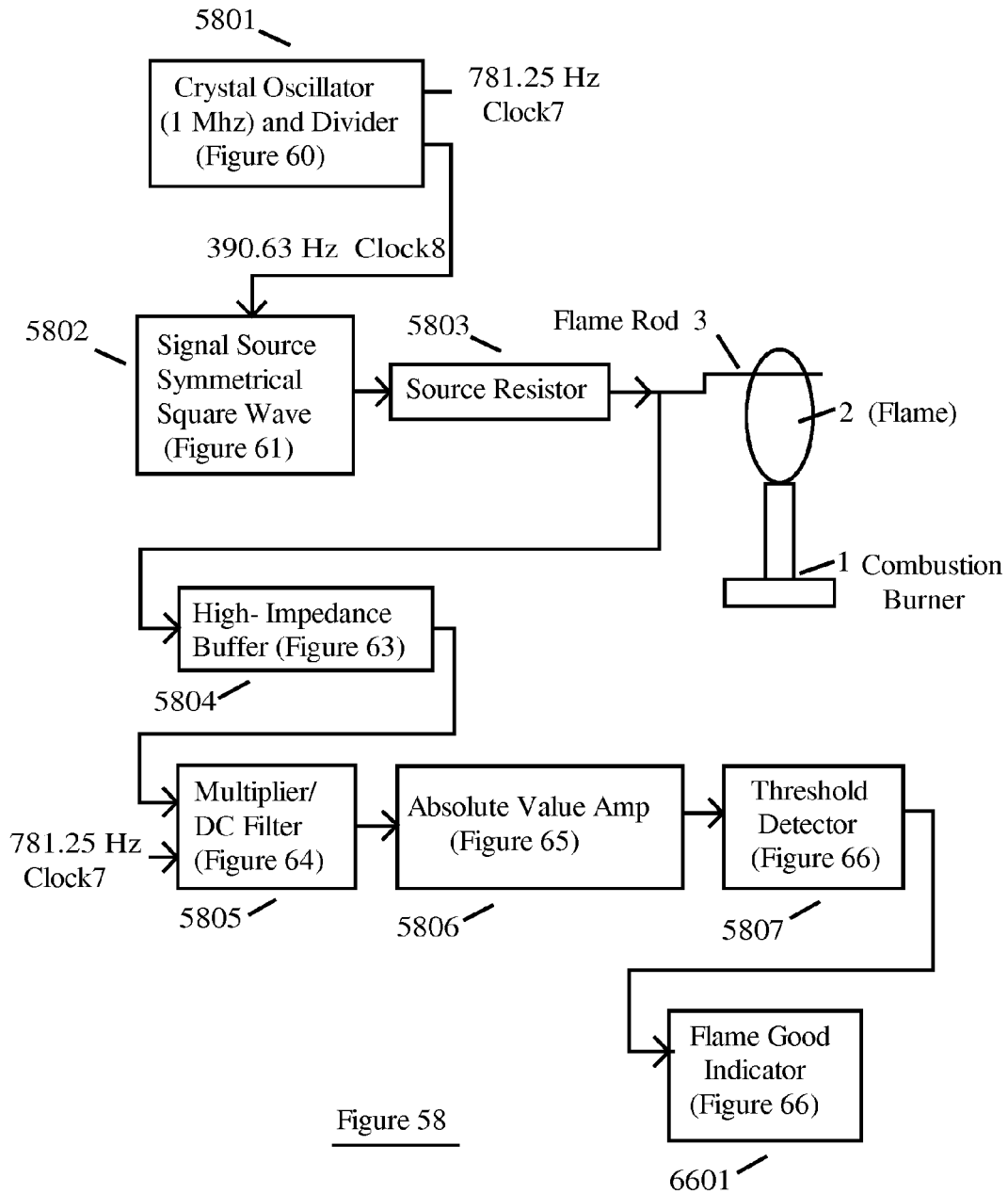

Figure 58

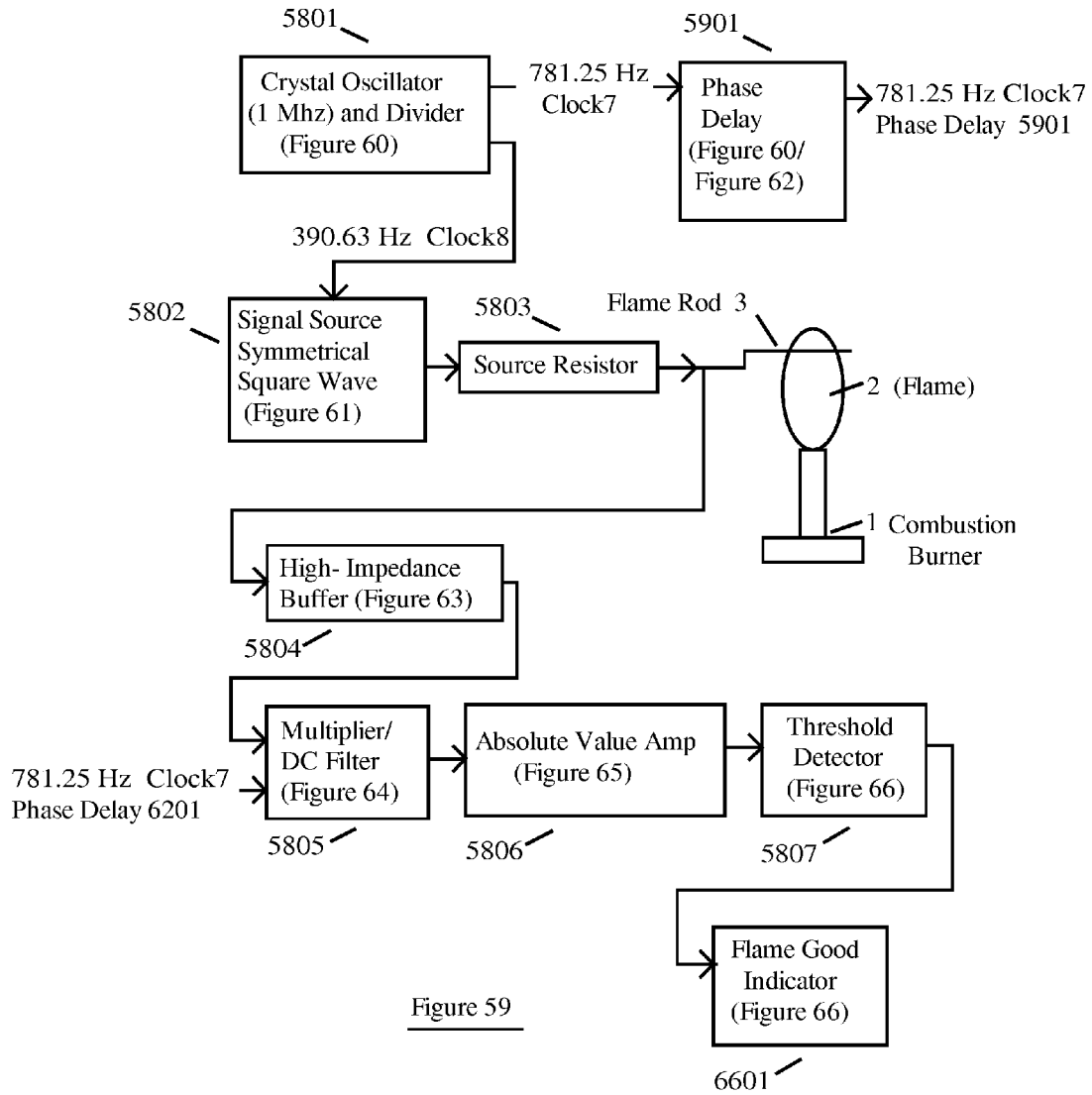

Figure 59

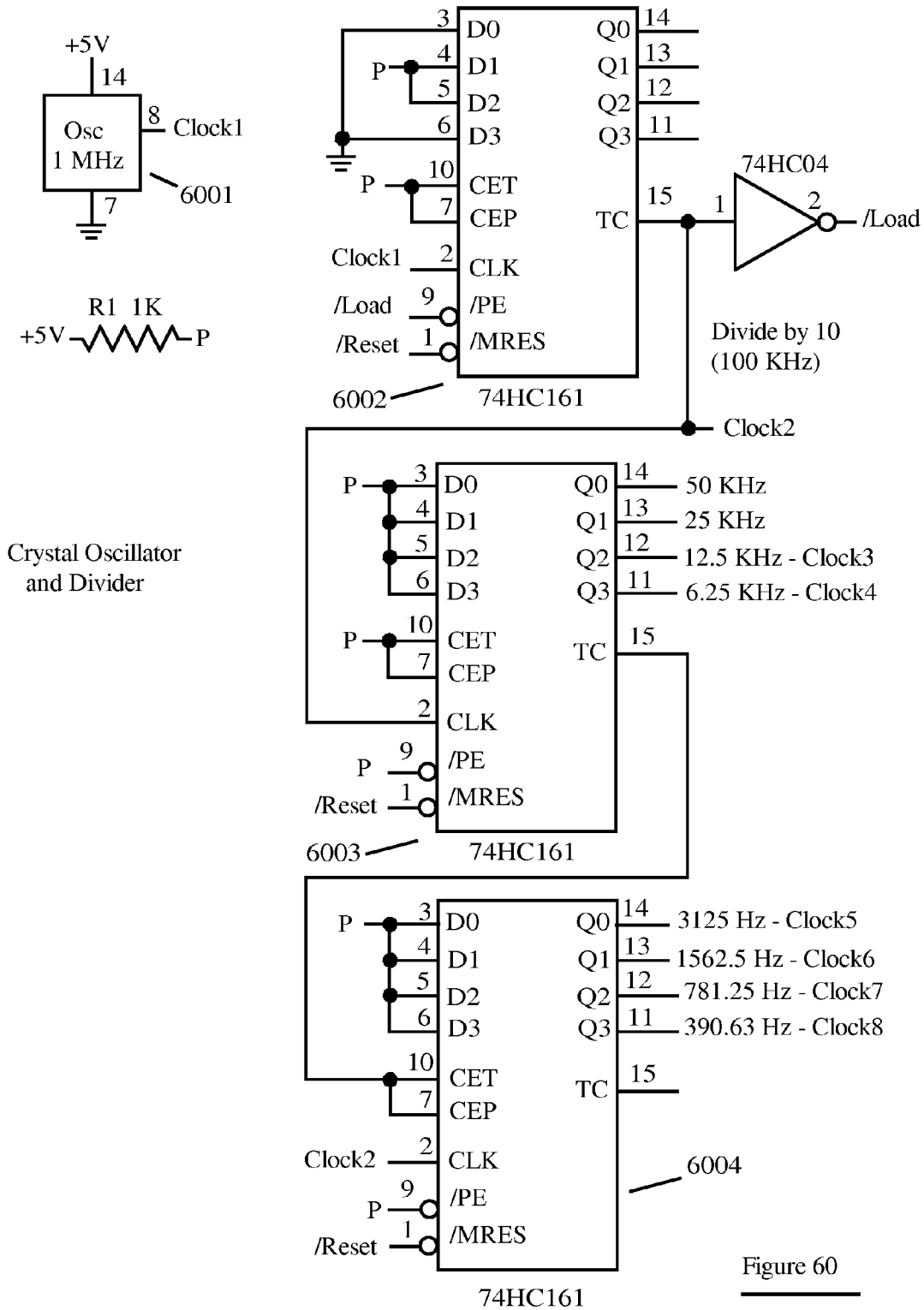

Figure 60

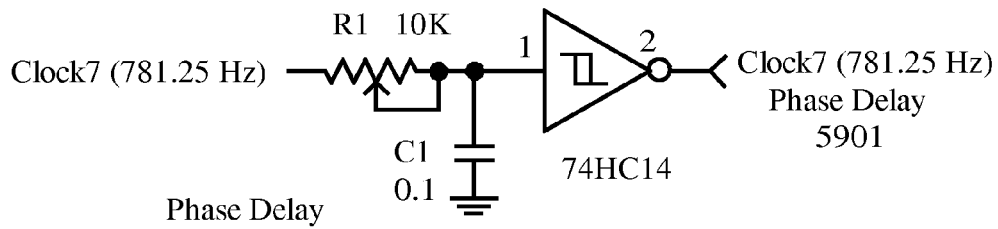
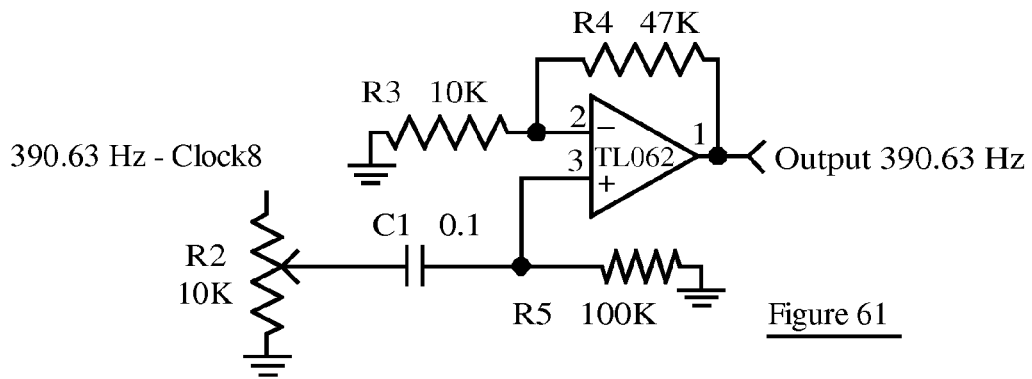

Figure 62

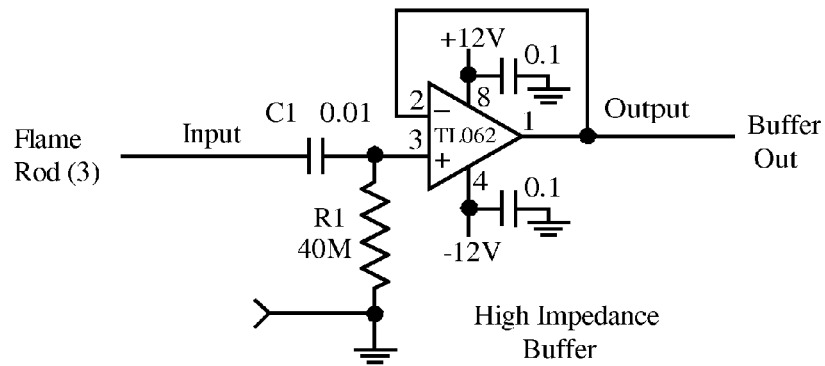

Figure 63

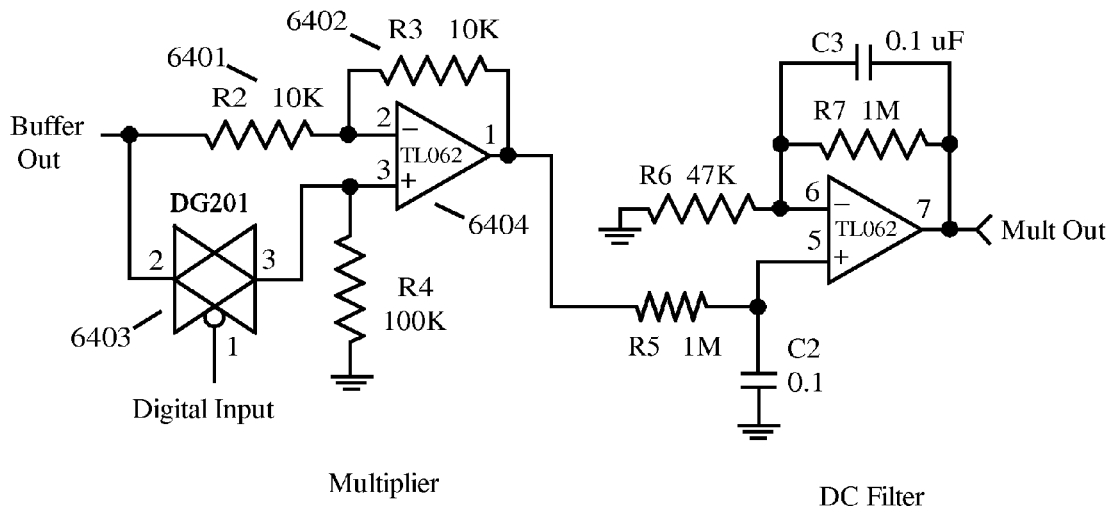

Figure 64

Multiplier and DC Filter

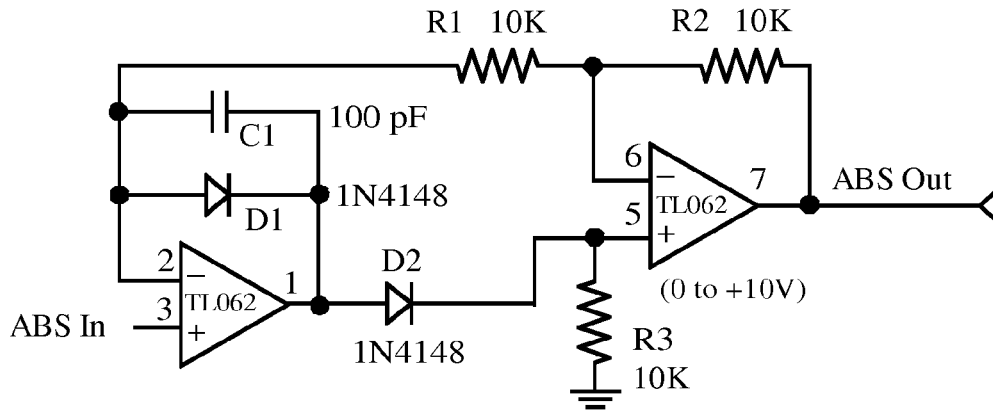

Figure 65 Absolute Value Amp

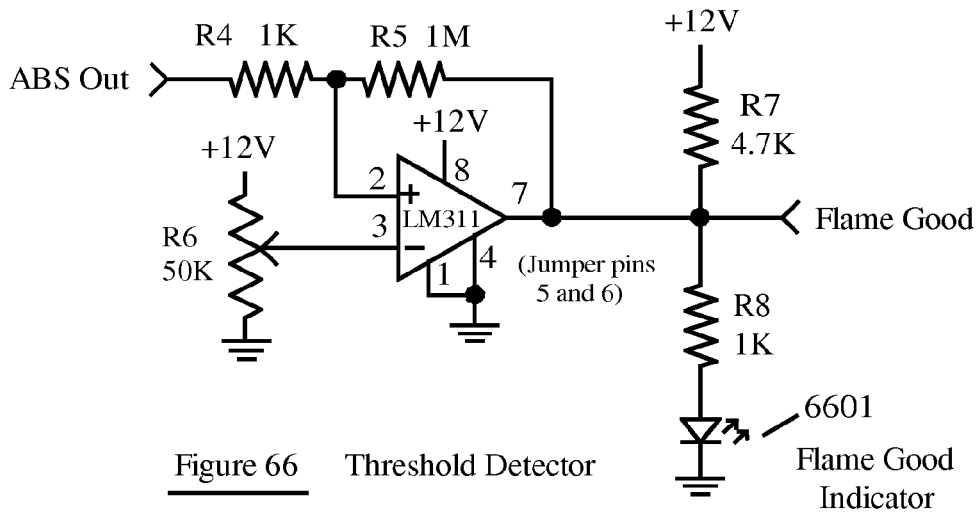

Figure 66 Threshold Detector

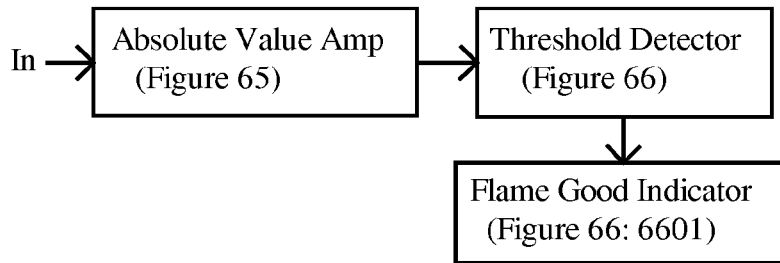
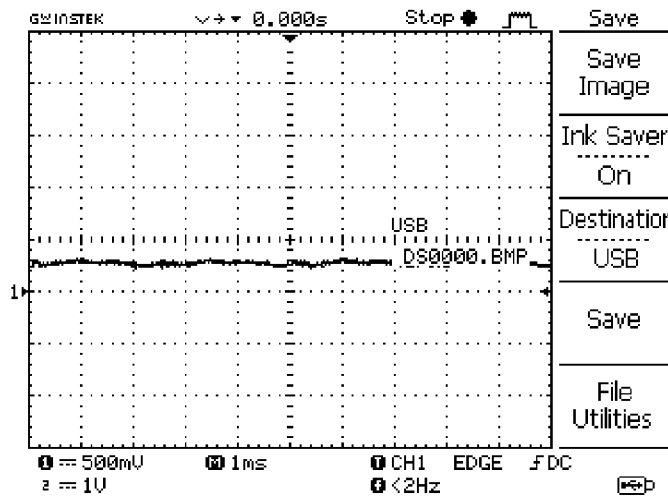
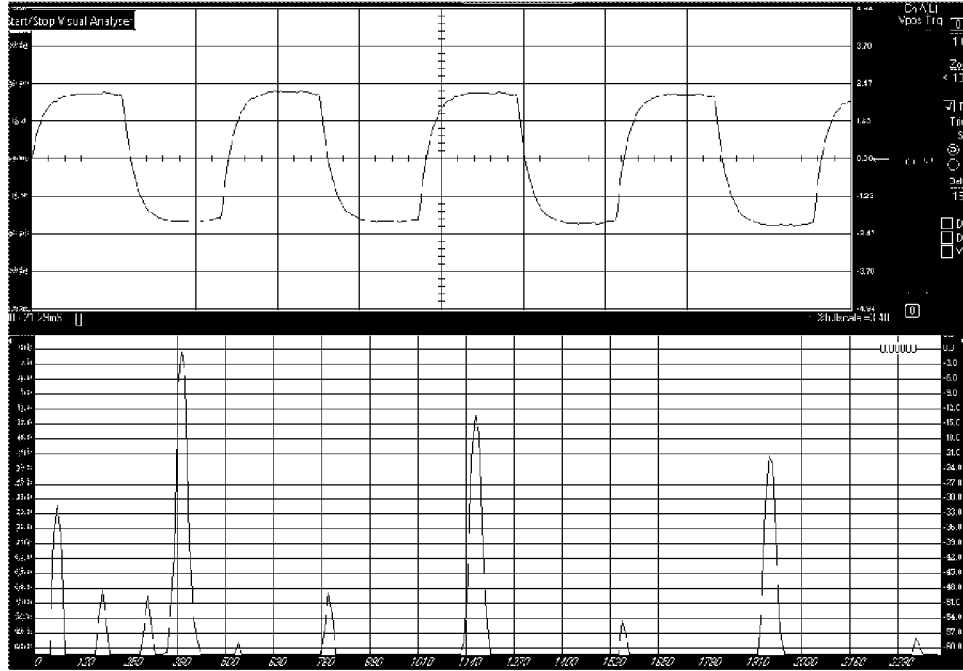
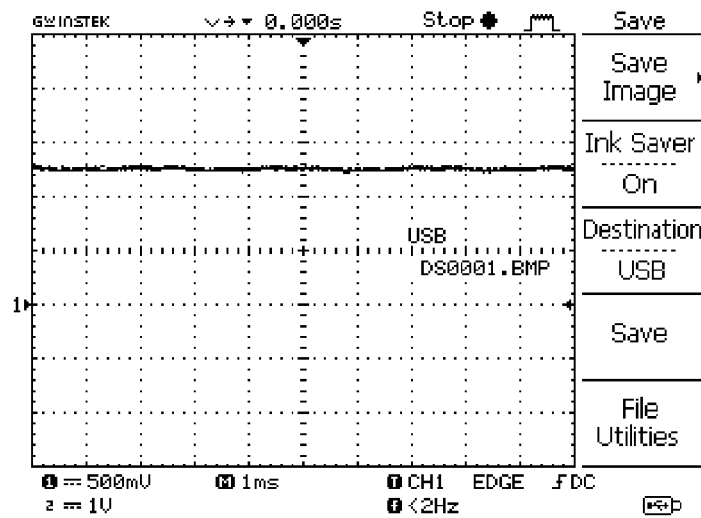
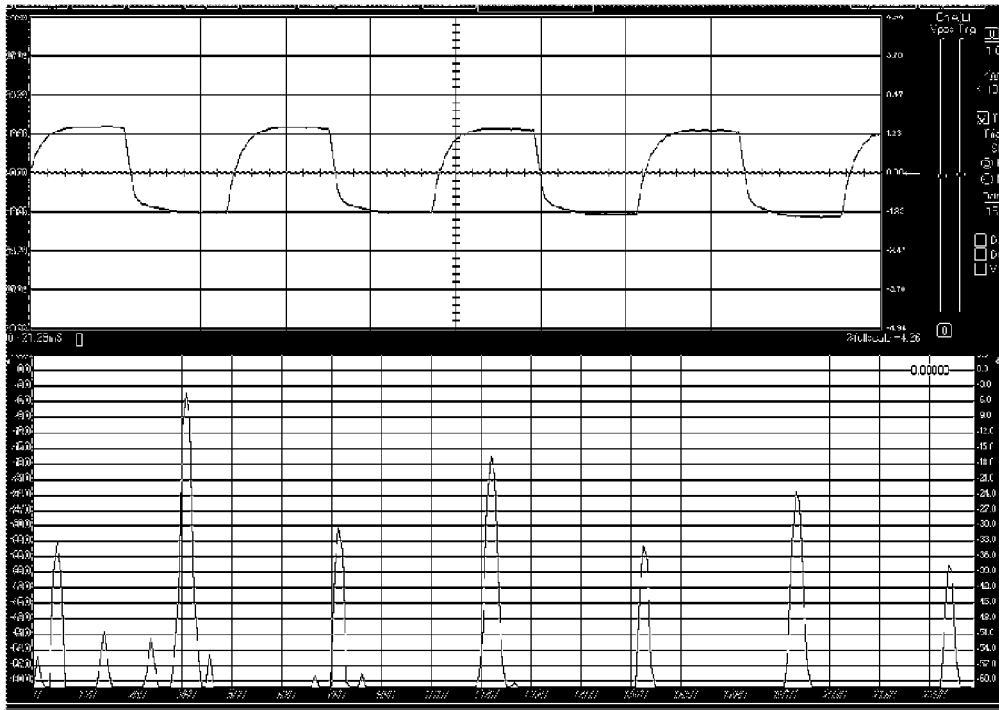

Figure 67 Threshold Detector



Experiment 14 Detecting a harmonic signal produced by flame rectification;
Signal Source: Symmetrical Square Wave
Detector: Simple Synchronous Detector
Flame: Off

Figure 68a



Experiment 14 Detecting a harmonic signal produced by flame rectification;
Signal Source: Symmetrical Square Wave
Detector: Simple Synchronous Detector
Flame: On

Figure 68b

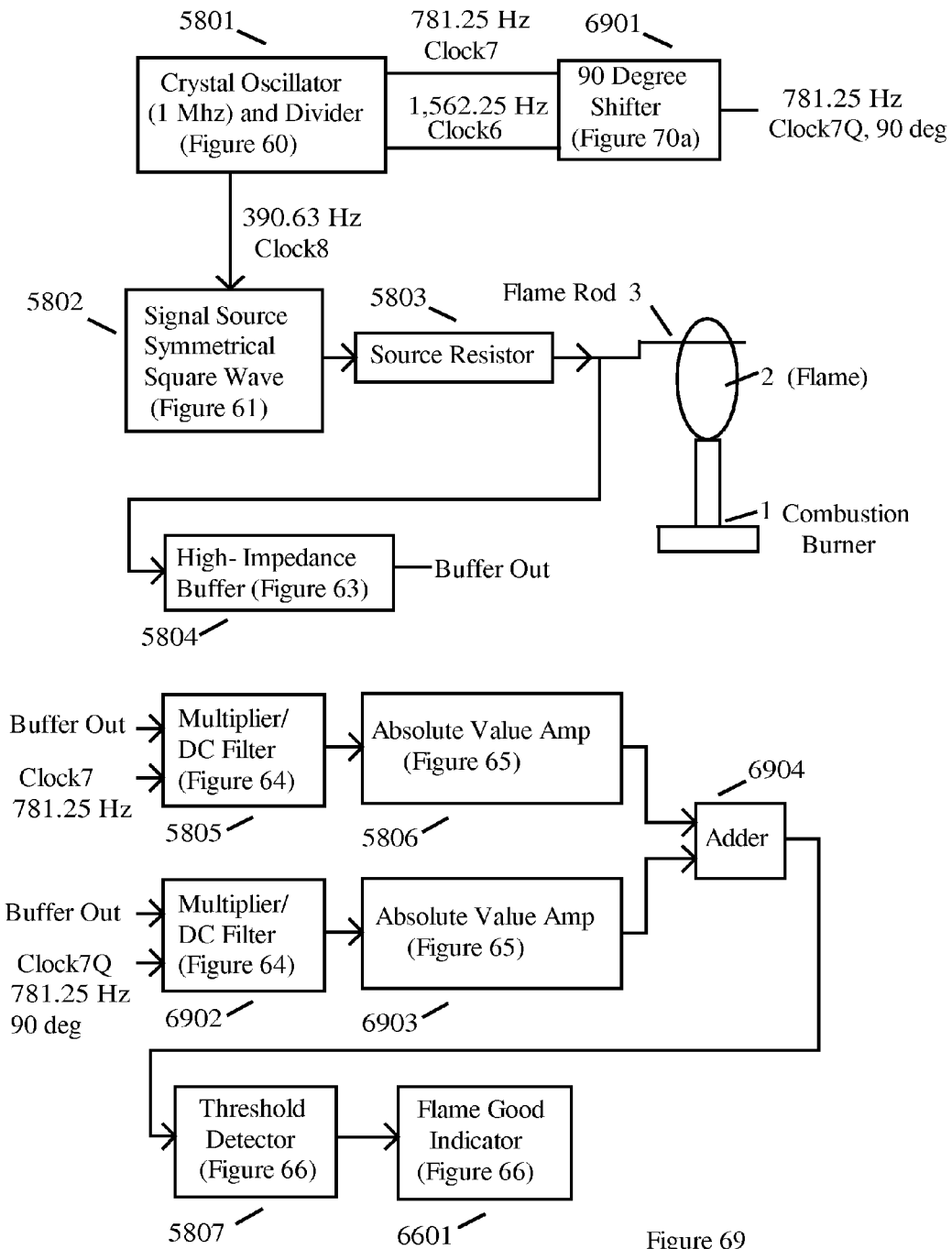

Figure 69

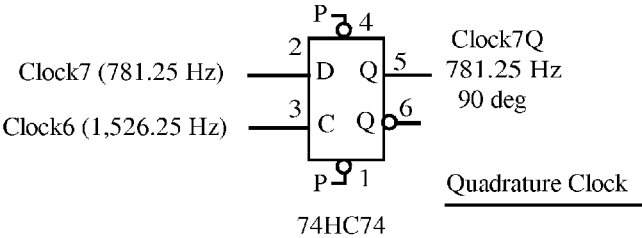

Figure 70a

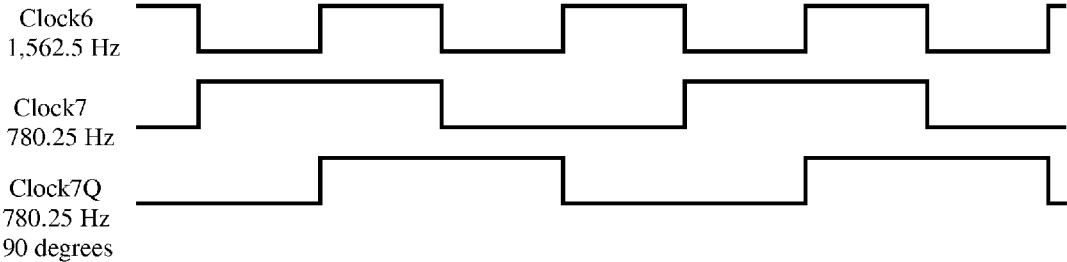

Figure 70b

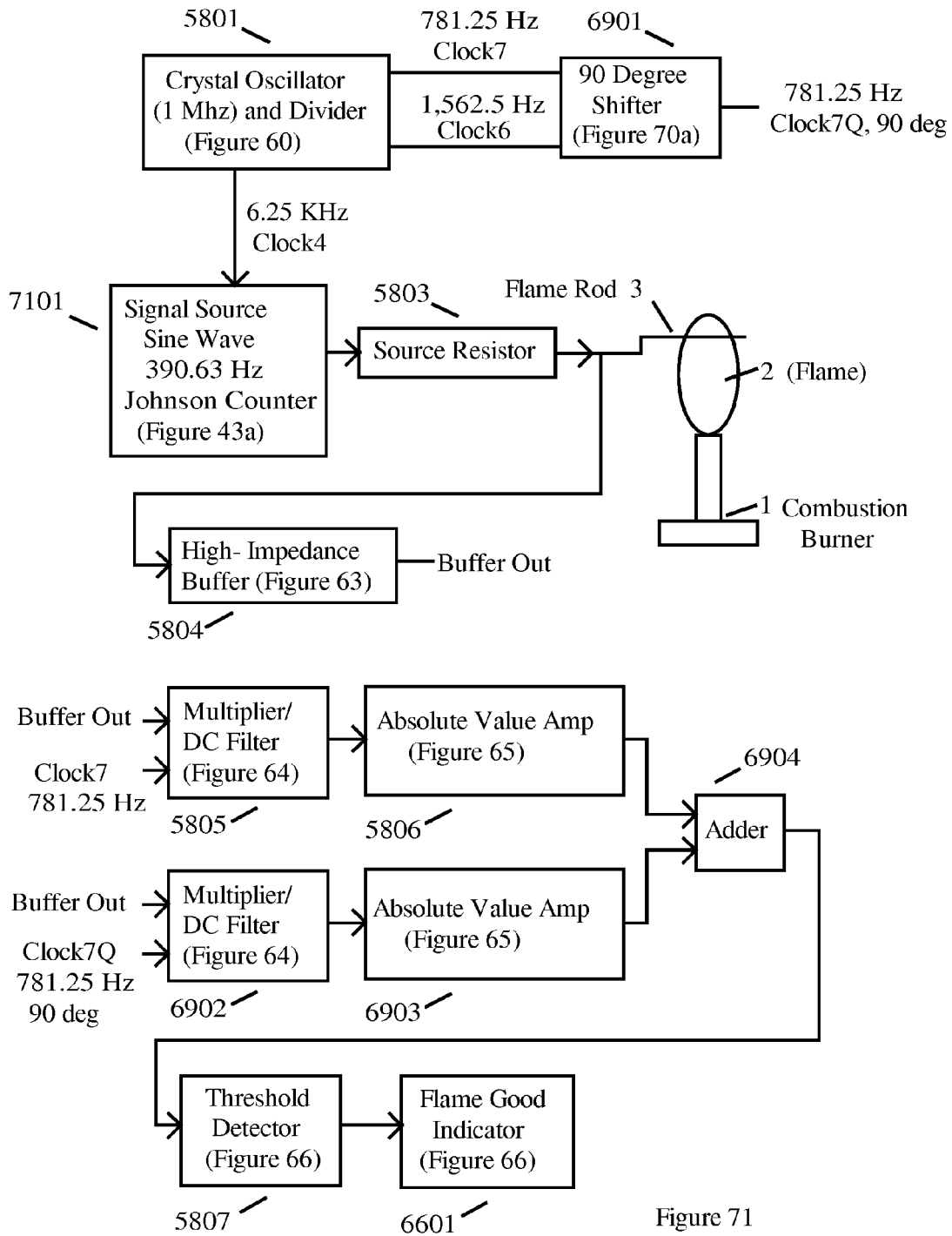

Figure 71

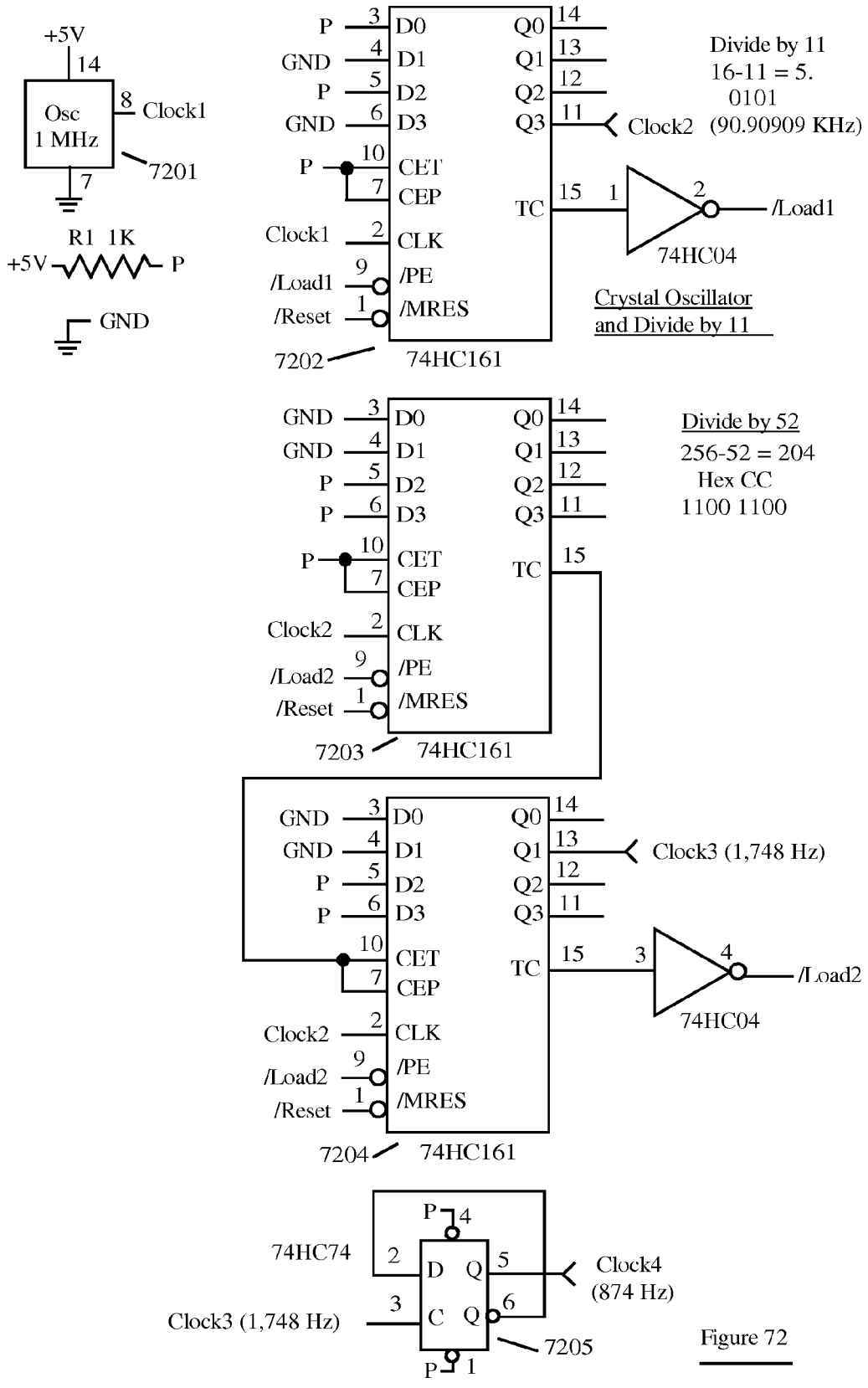
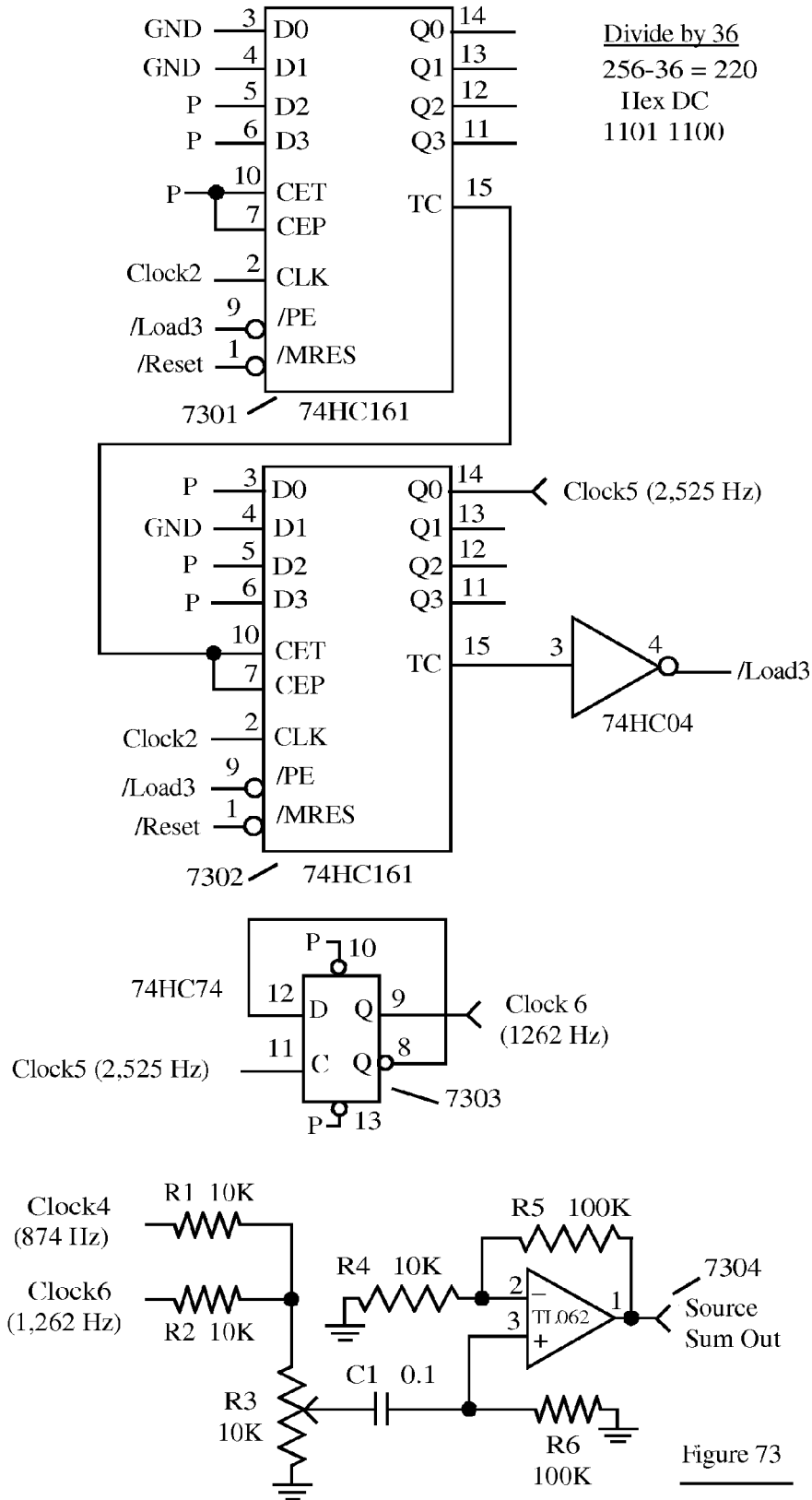

Figure 72



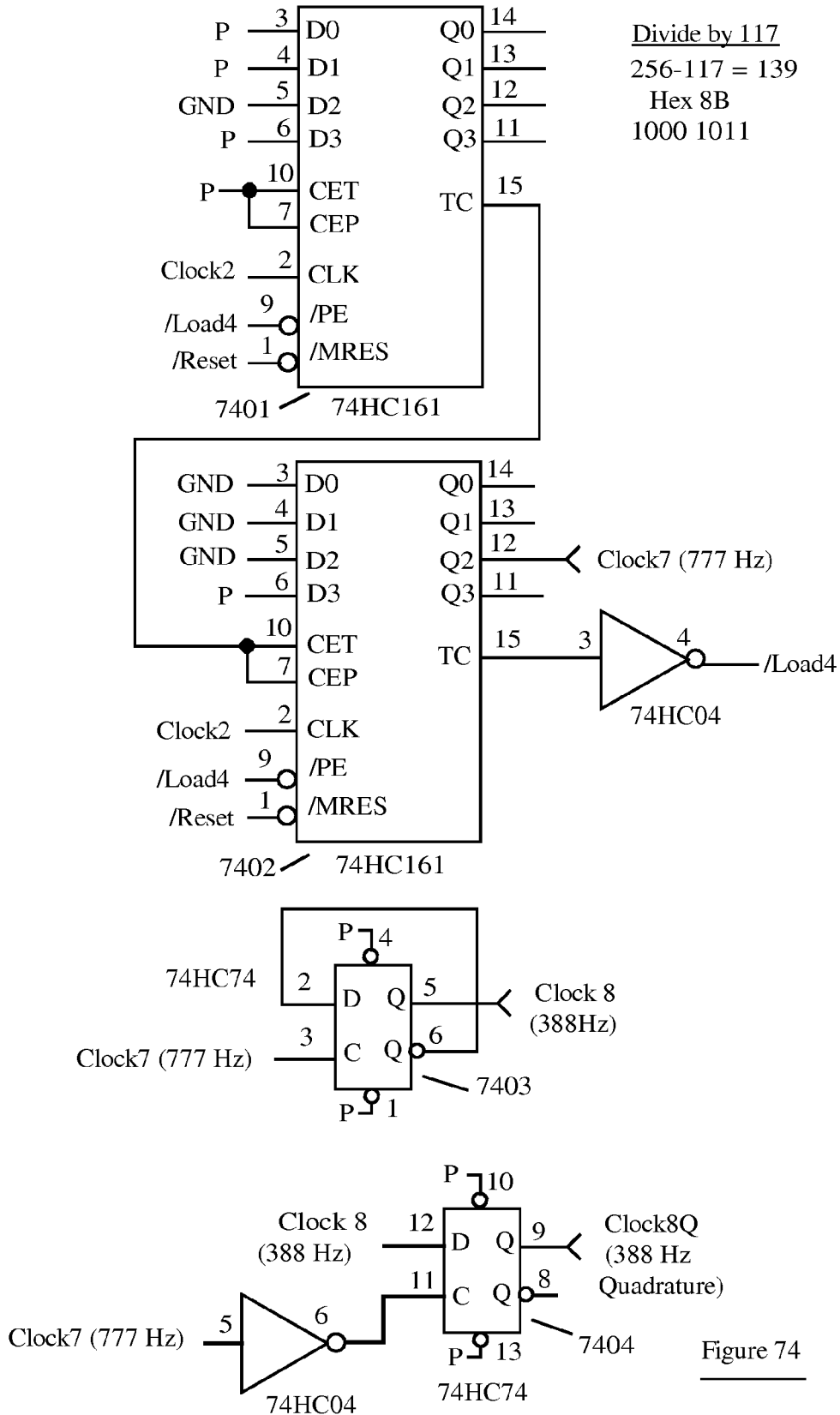

Figure 74

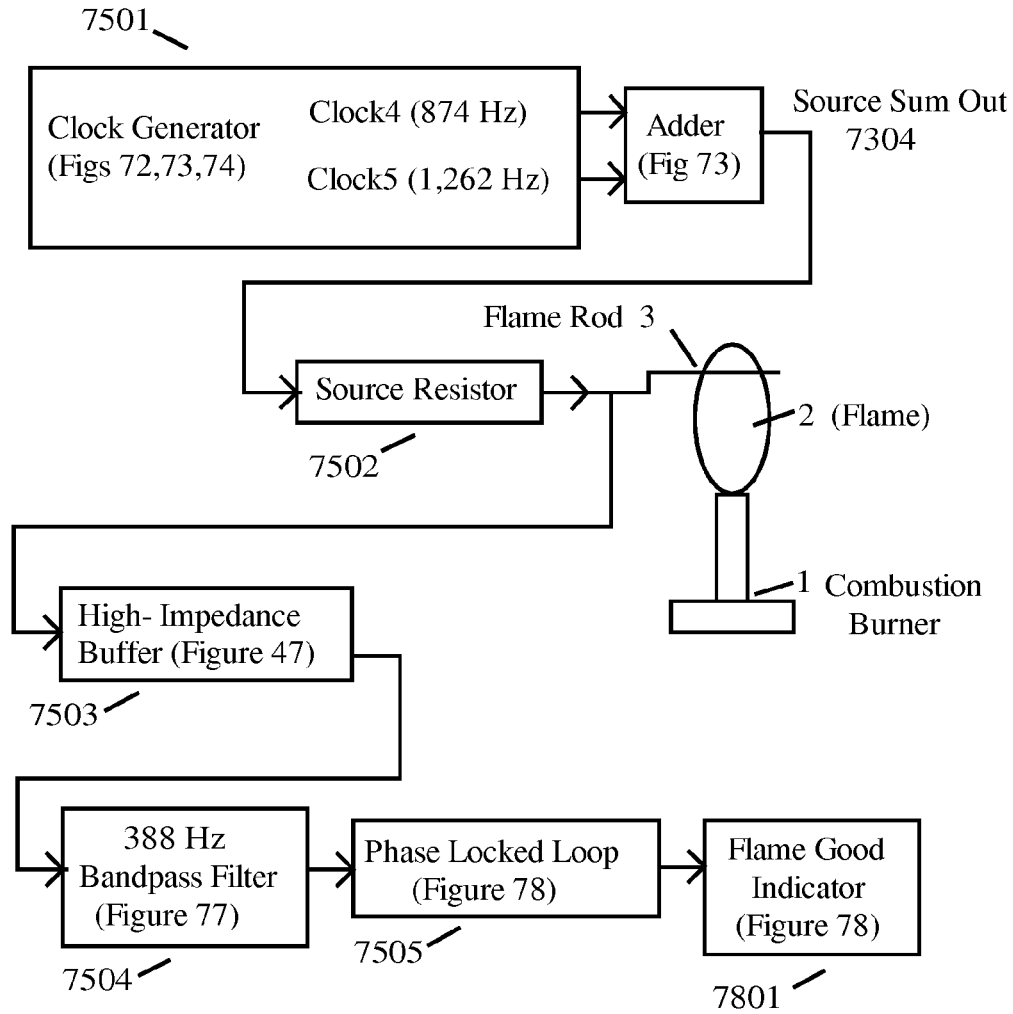

Figure 75

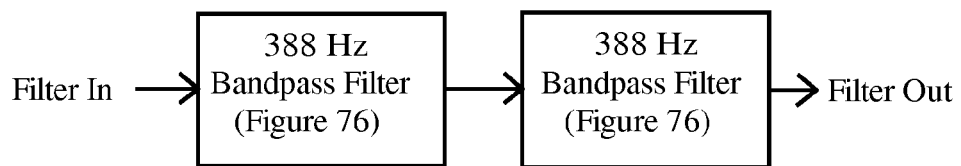
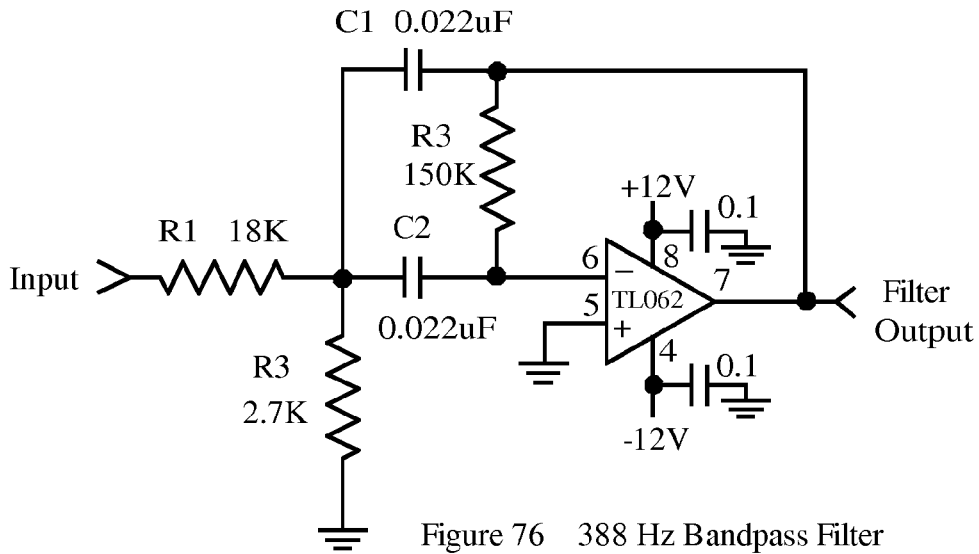

Figure 77 Two Cascaded Bandpass Filters

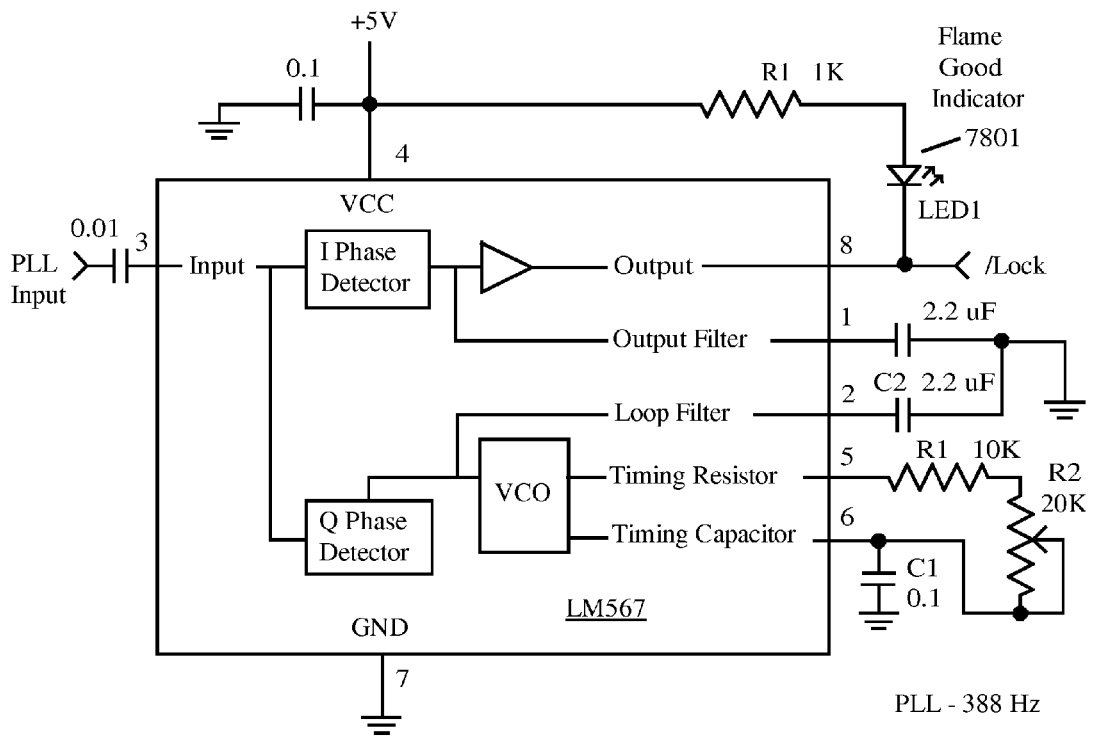

Figure 78

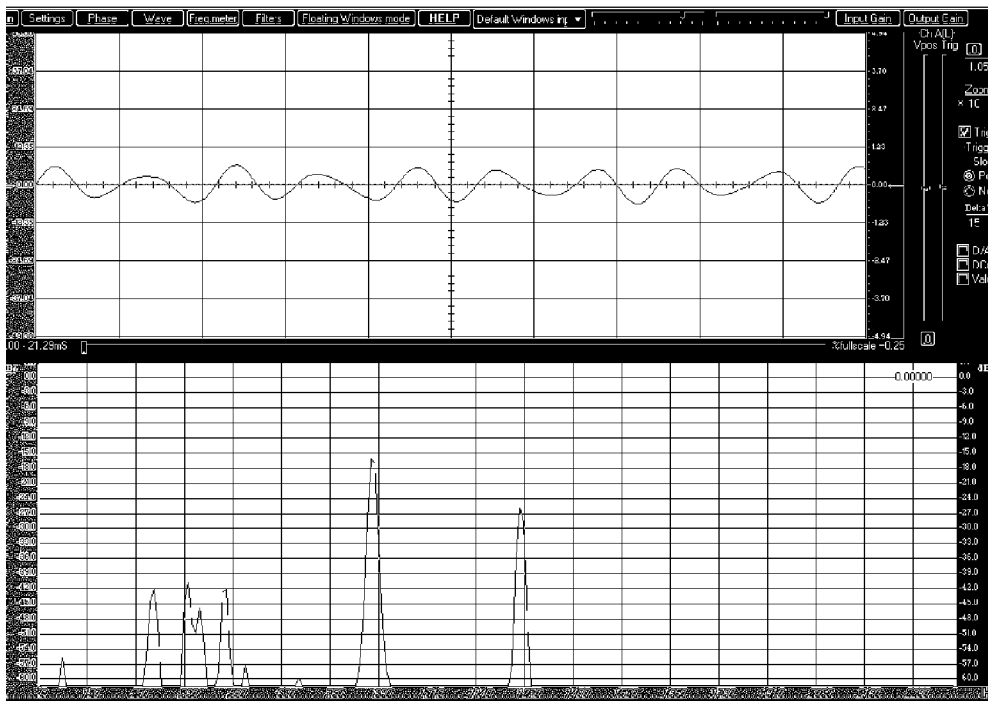

Figure 79a – Heterodyne Test – PLL Detector – Flame Off

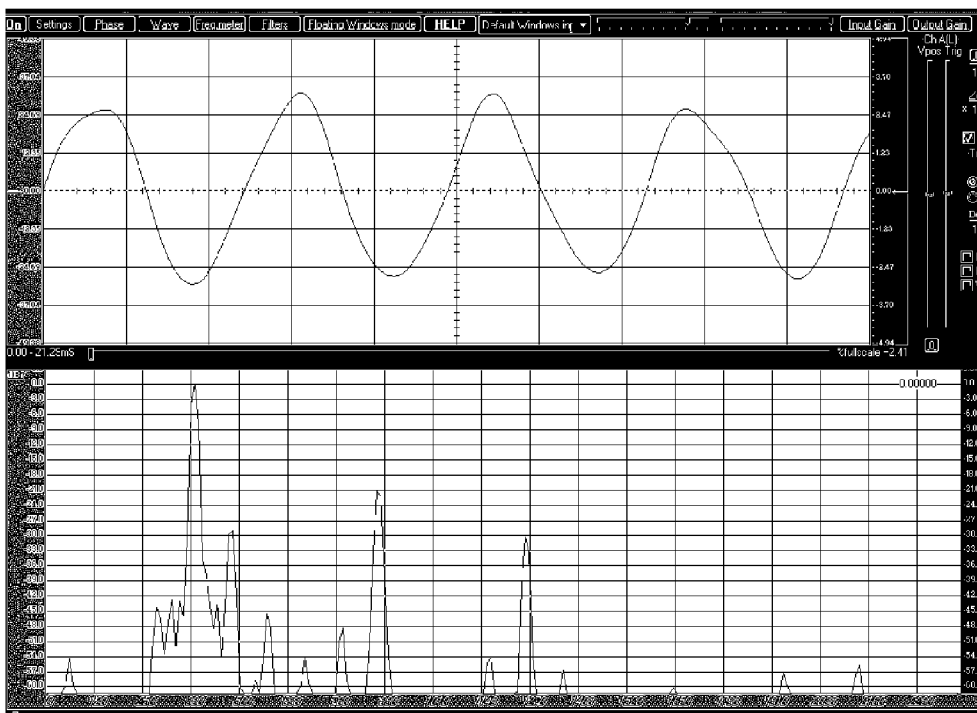

Figure 79b – Heterodyne Test – PLL Detector – Flame On

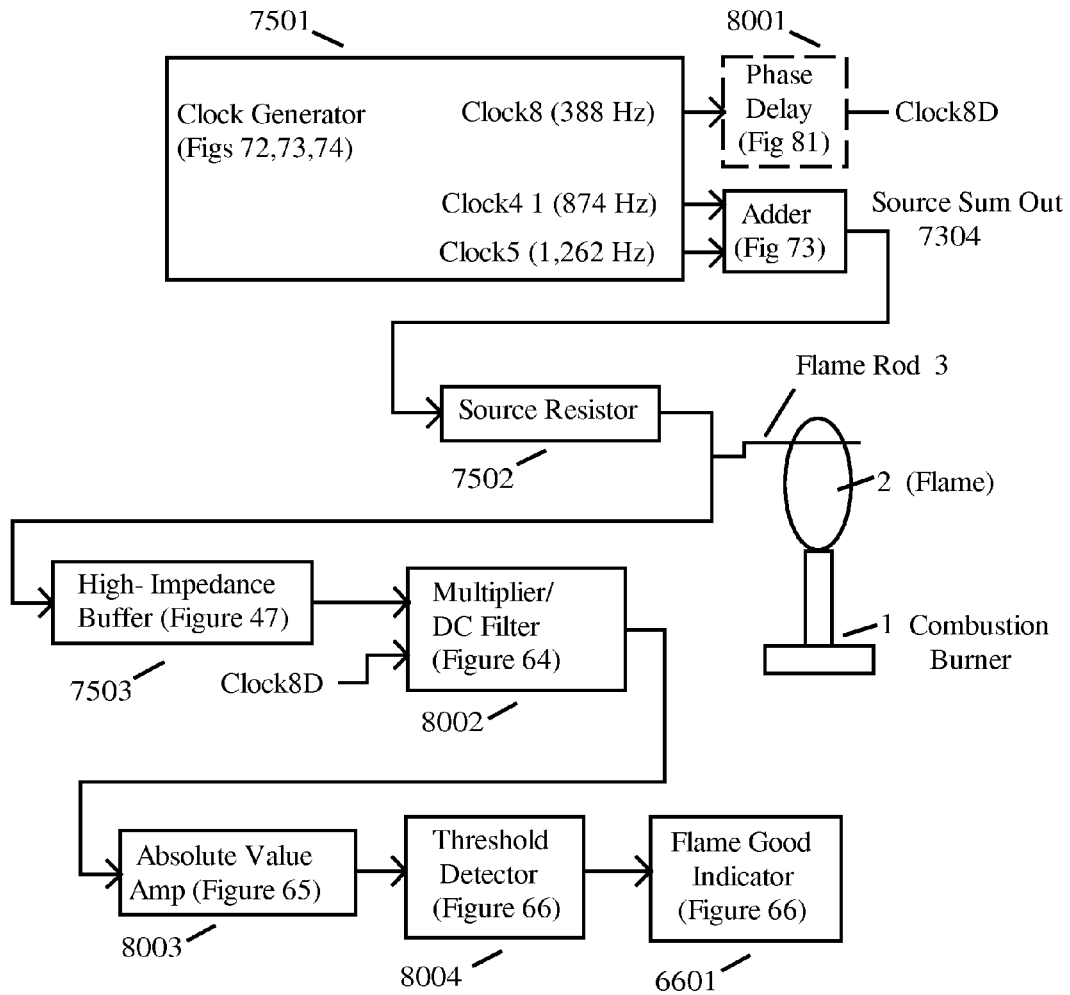

Figure 80

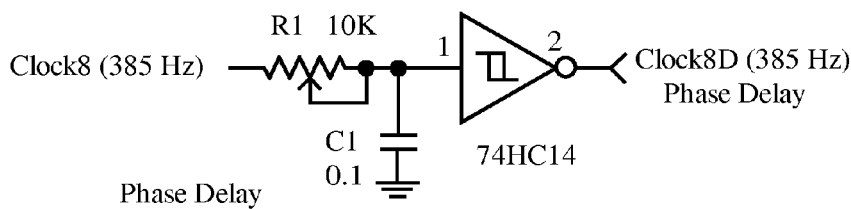

Figure 81

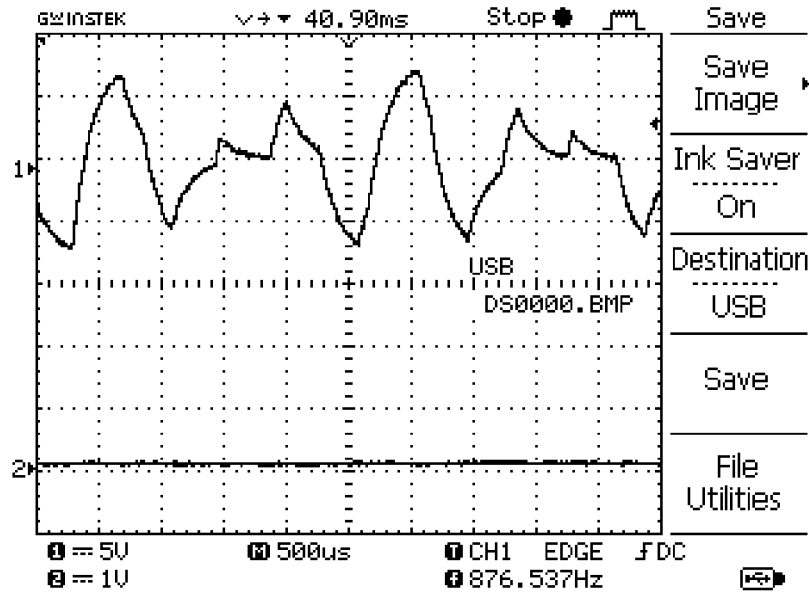

Figure 82a – Heterodyne Test – Simple Synchronous Detector – Flame Off

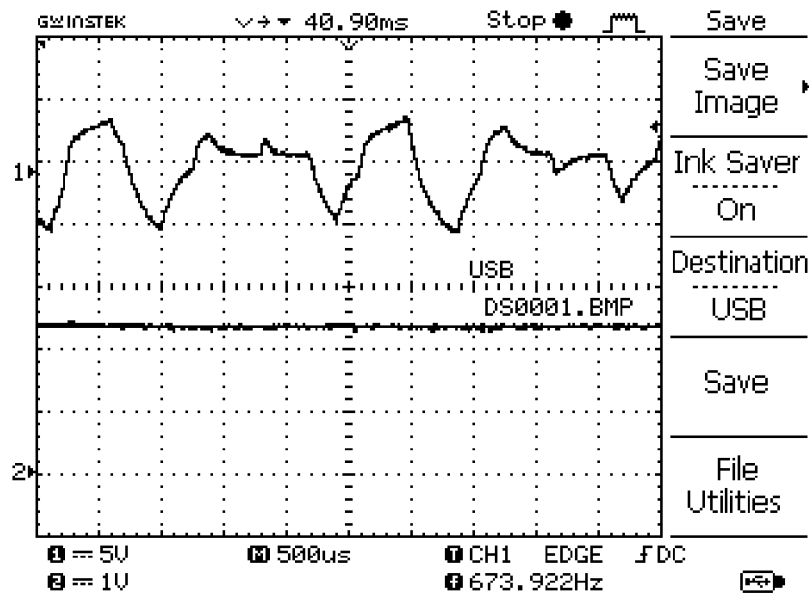

Figure 82b – Heterodyne Test – Simple Synchronous Detector – Flame On

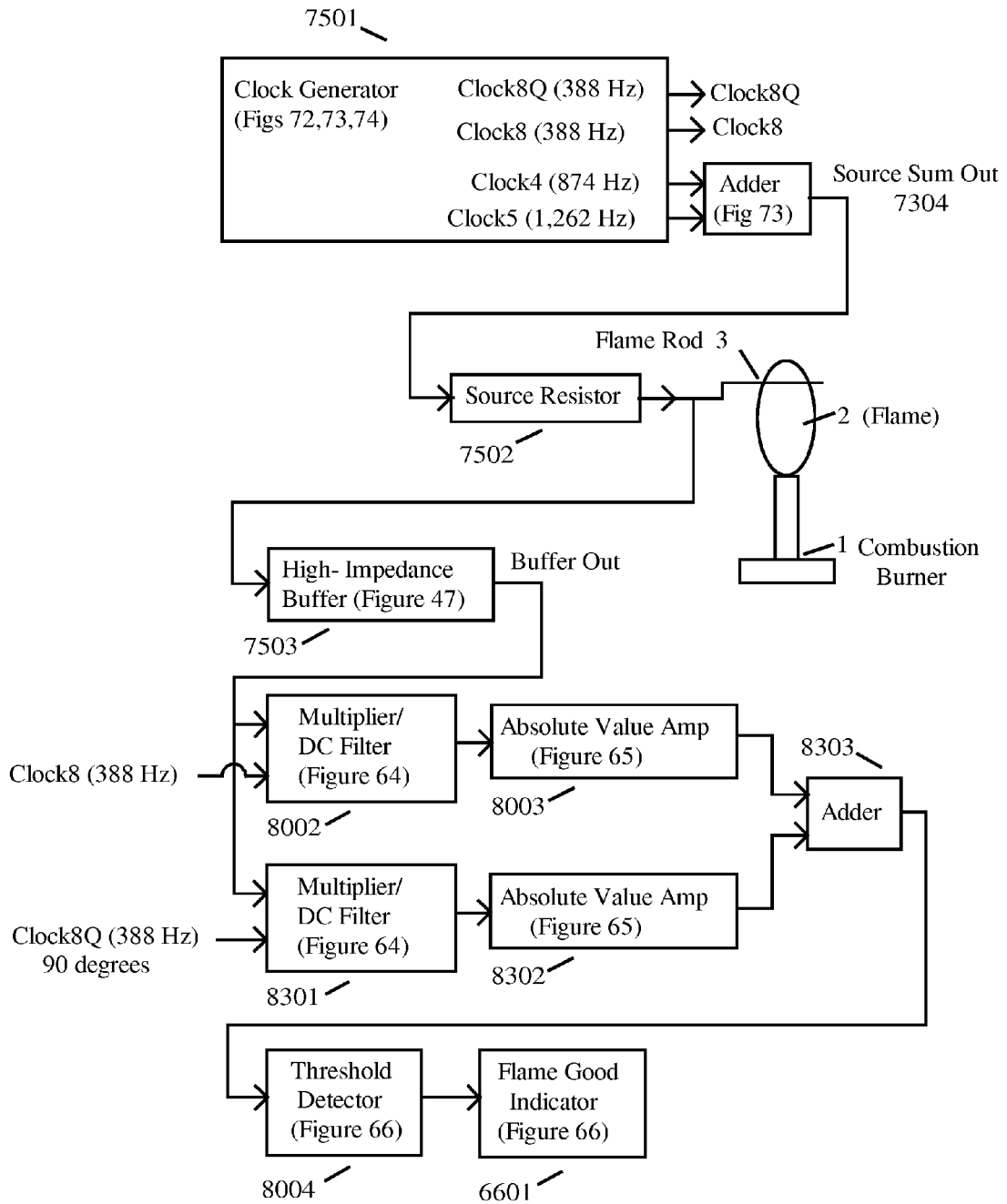

Figure 83

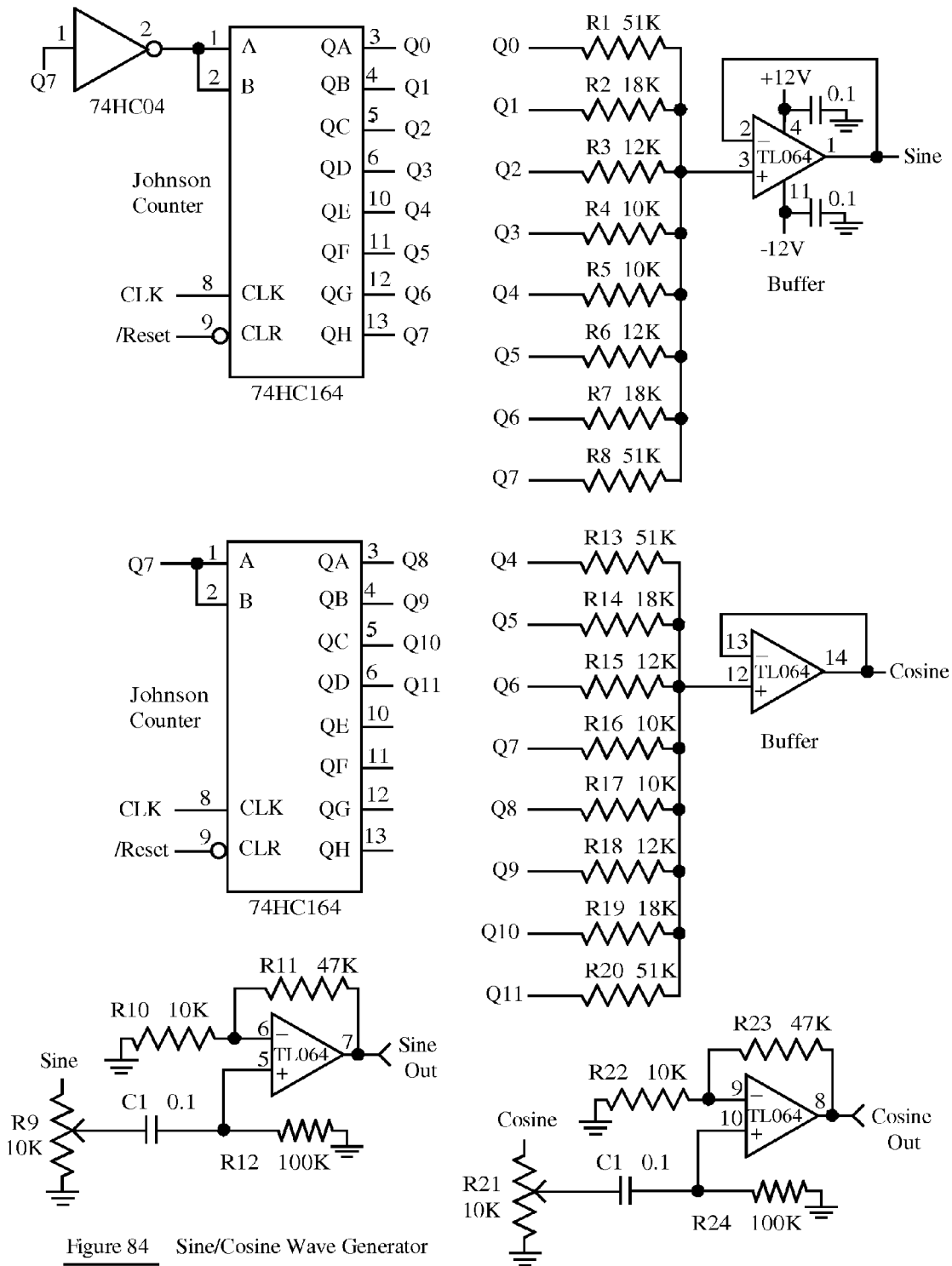

Figure 84 Sine/Cosine Wave Generator

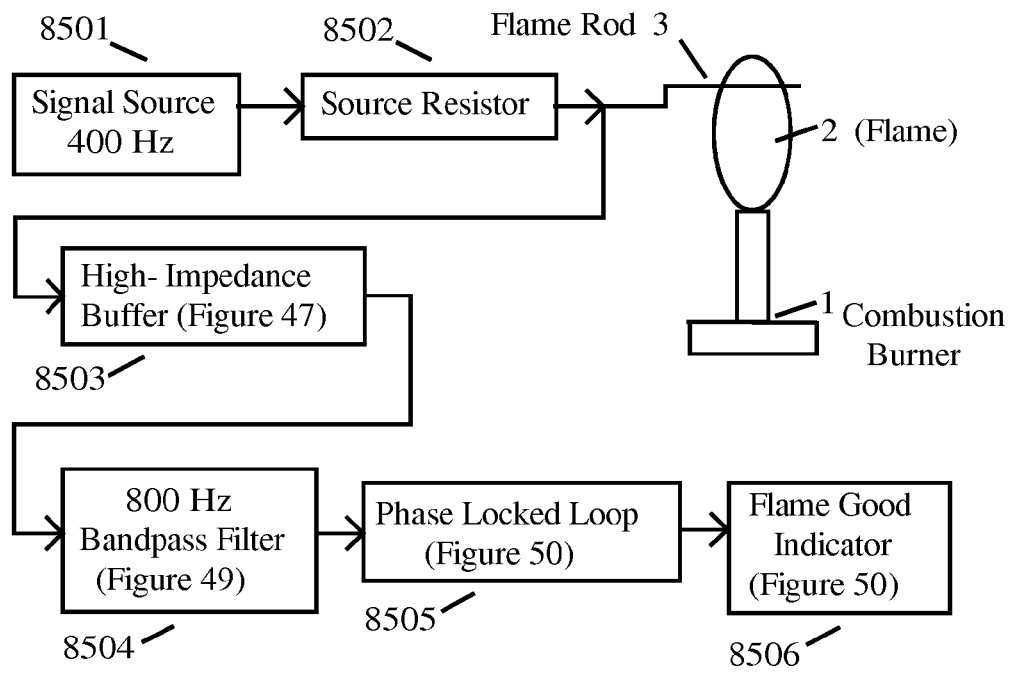

Figure 85

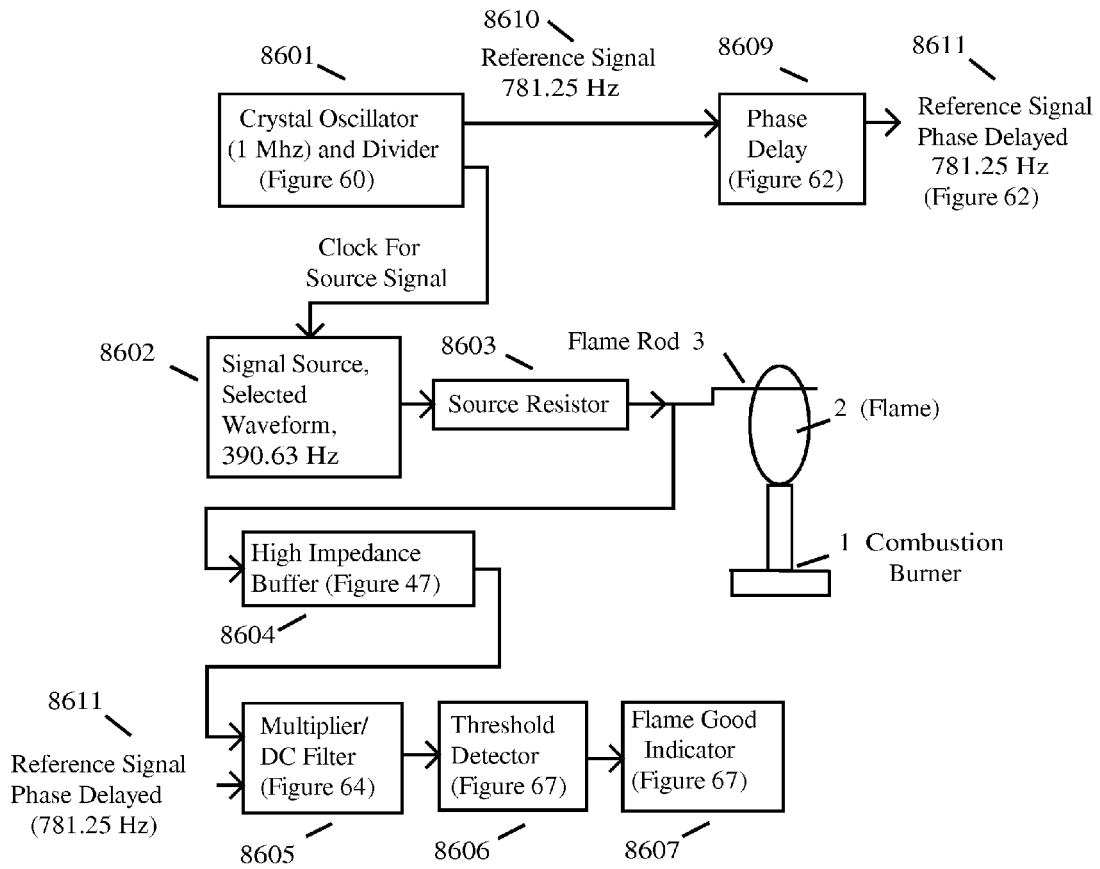

Figure 86

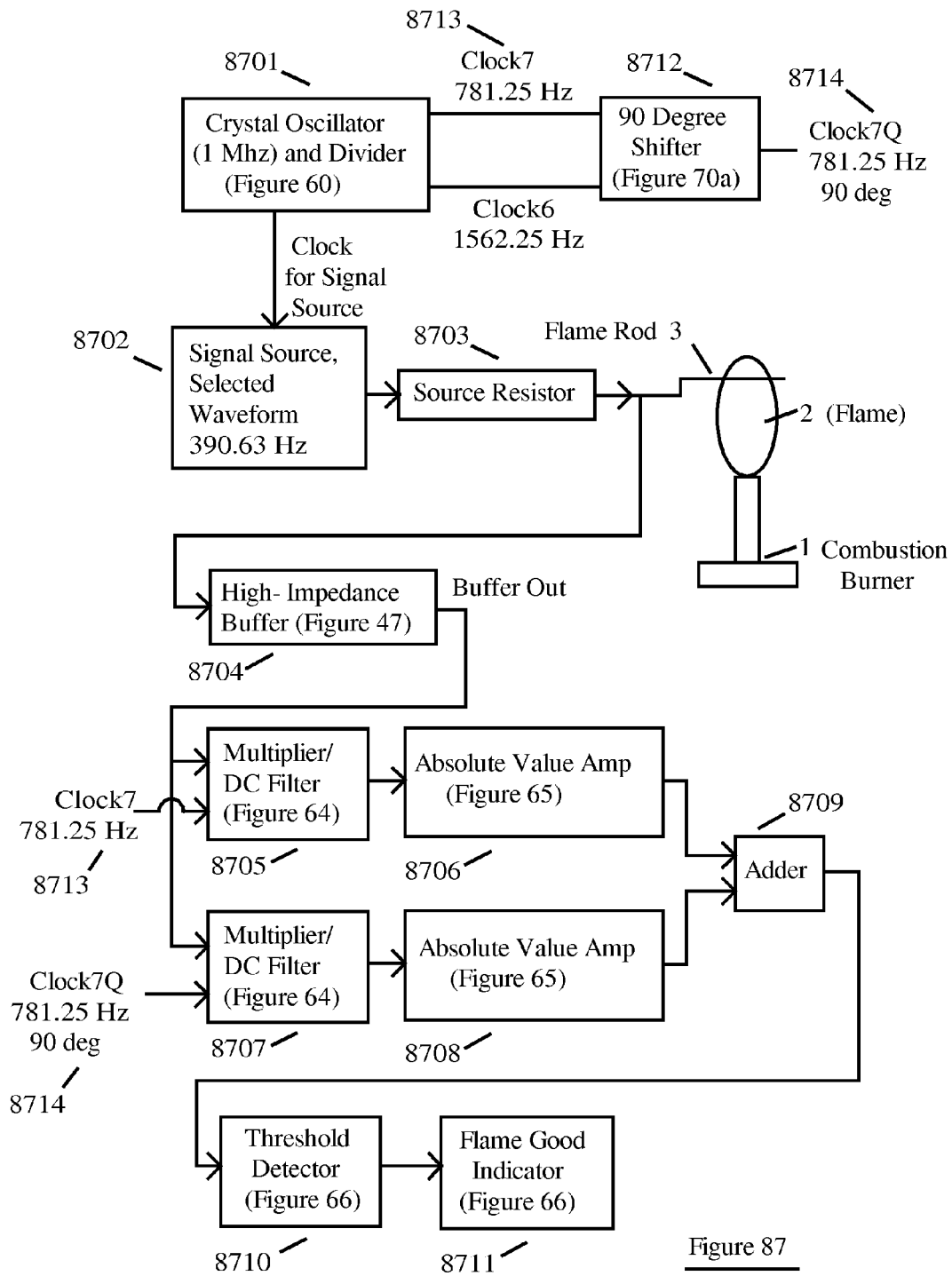

Figure 87

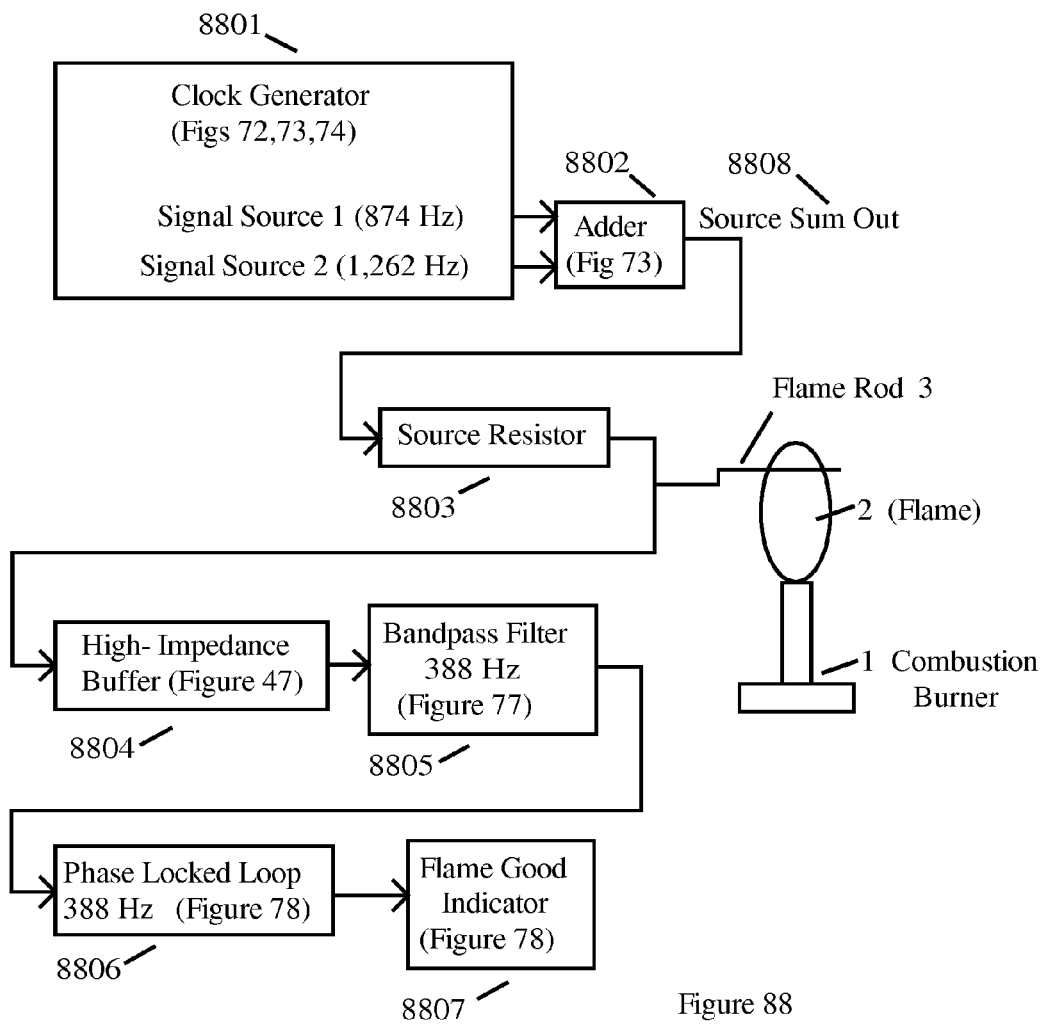

Figure 88

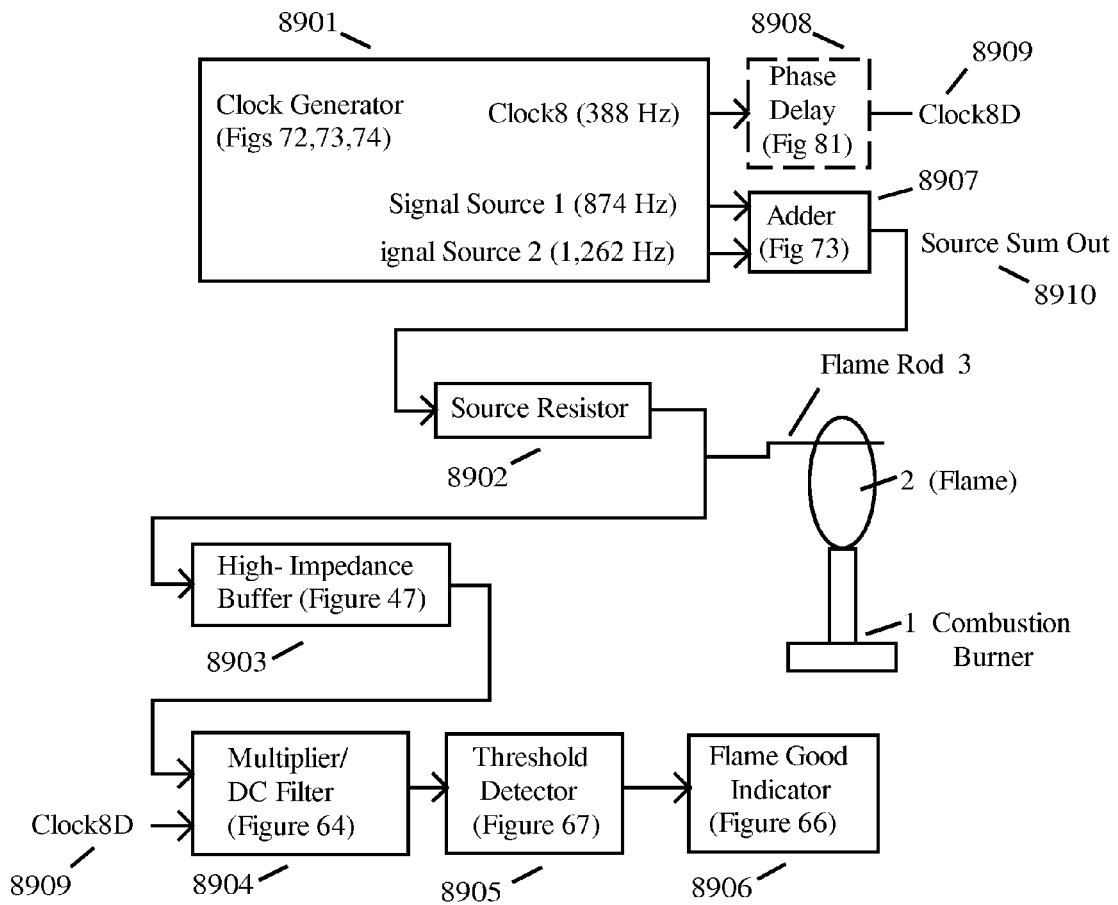

Figure 89

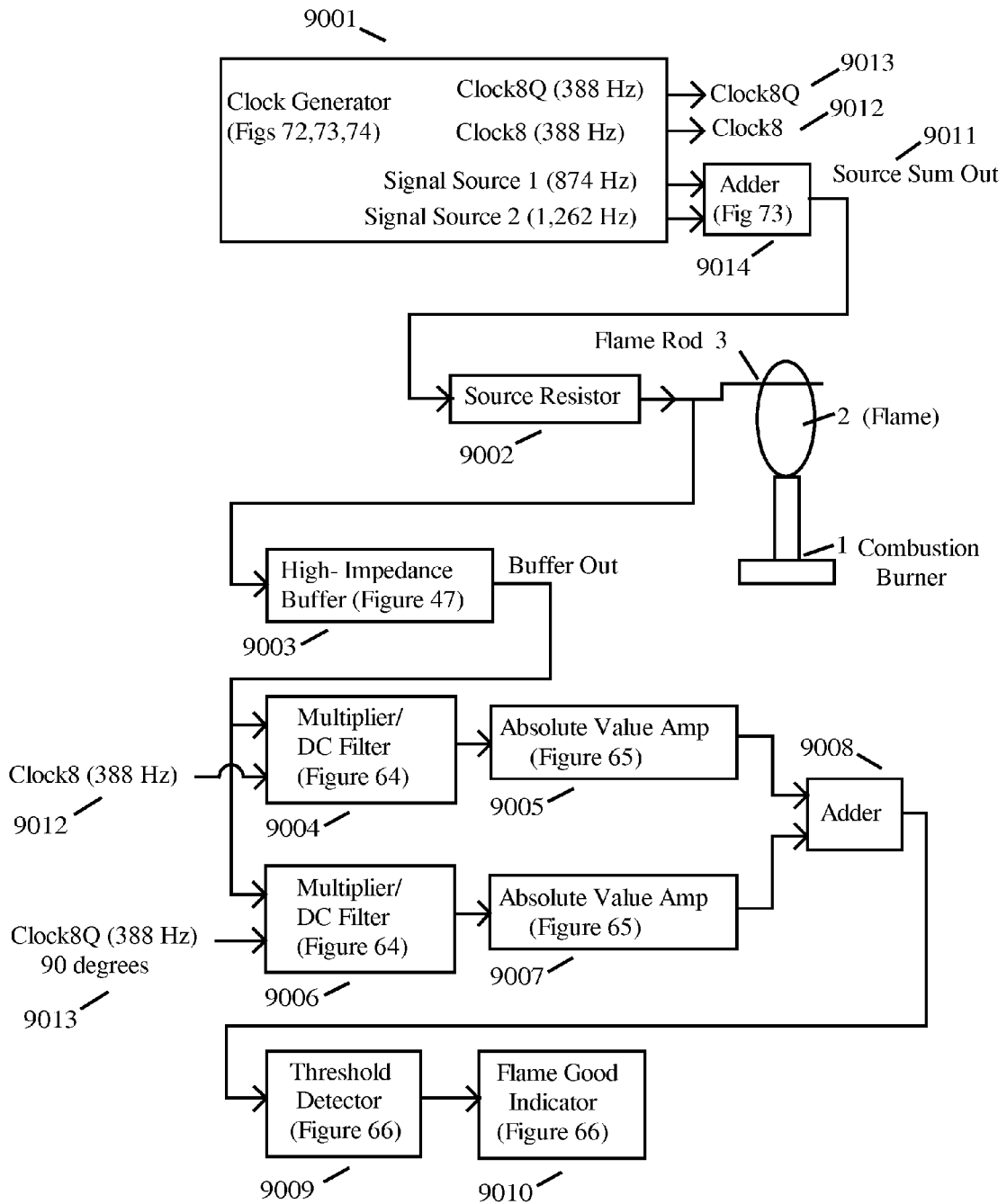

Figure 90